

NEW CONCORD ZONING CODE

Contents

- ARTICLE I TITLE AND ENACTMENT CLAUSE 6**
 - 100.01 Authority 6
 - 100.02 Title 6
 - 100.03 Purpose 6
- ARTICLE II DEFINITIONS 7**
 - 200.01 Definitions 7
- ARTICLE III GENERAL PROVISIONS 20**
 - 300.01 Establishment of Districts 20
 - 300.02 Zoning District Map 20
 - 300.03 Zoning District Boundaries 20
 - 300.04 Compliance with Regulations 20
 - 300.05 Interpretation and Conflict 20
- ARTICLE IV DISTRICT USE REGULATIONS AND DEVELOPMENT STANDARDS 22**
 - 400.01 S-1 Open Space & Conservation District 22
 - 400.02 R-1 Suburban Single Family Residential District 22
 - 400.03 R-2 Medium Density Residential District 22
 - 400.04 R-3 Multi-Family Residential District 22
 - 400.05 O-I Office-Institutional District 22
 - 400.06 B-1 Local Business District 22
 - 400.07 B-2 Central Business District 23
 - 400.08 B-3 Highway Business District 23
 - 400.09 I-1 General Industrial District 23
 - 400.10 Use Regulations – S-1 through I-1 23
 - 400.11 Development Standards – Lots and Principal Buildings 32
 - 400.12 Development Standards – Accessory Buildings 35
 - 400.13 Development Standards – Minimum Floor Area For Dwellings 35
 - 400.14 Planned Unit Development (PUD) District 36
- Article V OVERLAY DISTRICTS 41**
 - 500.01 Overlay Districts 41
 - 500.02 ARD Architectural Review District Overlay 41
 - 500.03 Certificate of Appropriateness Required 41
 - 500.04 Establishment of a Design Review Board 41
 - 500.05 Composition and Organization of the Design Review Board 41
 - 500.06 Duties of the Design Review Board 41
 - 500.07 Design Requirements & Review Criteria 42
 - 500.08 Procedures 43
 - 500.09 Appeals 43
 - 500.10 State Route 83 Corridor Overlay District 43
 - 500.11 Requirements: 43
- ARTICLE VI SUPPLEMENTAL CONDITIONS 44**
 - 600.01 Buffering Requirements 44
 - 600.02 Adjustments to Side Yard Requirements For Corner Lots 44
 - 600.03 Visibility at Intersections 44
 - 600.04 Architectural Projections 44
 - 600.05 Double Frontage Lots 44
 - 600.06 Accessory Buildings 44
 - 600.07 Fences, Walls and Hedges 44
 - 600.08 Swimming Pools 45
 - 600.09 Club Swimming Pools: 45
 - 600.10 Outdoor Lighting 45

600.11	Bed & Breakfast Establishments	45
600.12	Parking or Storage of Trailers, Recreation Vehicles and Boats	45
600.13	Height Regulations for Structures	46
600.14	Requirement for Sexually-Oriented Businesses.....	46
600.15	Minimum Standards for Single Family Dwellings	46
600.16	Outdoor Storage Restrictions	46
600.17	Temporary Buildings	46
600.18	Satellite Dish Receivers.....	47
600.19	Conversion of Dwellings.....	47
600.20	Street Access-Curb Cuts-Driveways	47
600.21	Out-Door Furnaces.....	47
600.22	Parking Area Maintenance.....	47
600.23	Generators and Turbines	48
600.24	Roof Mounted Solar Collection Systems and Free Standing Solar Collection Systems	48
600.25	Roof Mounted Solar Collection Systems	48
600.26	Roof Mounted Solar Collection Systems in Architectural Review Overlay District	48
600.27	Free Standing Solar Collection Systems – under 25,000 Sq. Ft. in total area.	48
600.28	Free Standing Solar Collection Systems–more than 25,000 Sq.Ft. & under 100,000 Sq.Ft. Error! Bookmark not defined.	
600.29	Mobile Retail Food Establishment Court.....	47
ARTICLE VII OFF-STREET PARKING AND LOADING REQUIREMENTS.....		57
700.01	Off-street Parking - General Requirements.....	57
700.02	Number of Spaces Required	57
700.03	Interpretation:	58
700.04	Special Parking Provisions.....	59
700.05	Screening	59
700.06	Parking Lot Landscaping.....	59
700.07	Dumpsters and Waste Receptacle Screening	59
700.08	Pedestrian Connections in Parking Lots from the Row to Entrances.....	59
700.09	Surfacing	60
700.10	Lighting:.....	60
700.11	Off street Loading Requirements	60
700.12	Location of Loading Spaces	60
ARTICLE VIII SITE PLAN REVIEW PROCEDURES.....		61
800.01	Site Plan Review – Purpose	61
800.02	Projects Requiring Site Plan Review	61
800.03	Site Plan Submissions.....	61
800.04	Site Plan Procedures.....	61
800.05	Submission Requirements	62
800.06	Plan Review.....	62
800.07	Advertisement of Pending Site Plan Action	62
800.08	Standards For Review	62
800.09	Enforcement And Time Limits	63
800.10	Site Plan Content.....	63
800.11	Traffic Impact Study	65
800.12	Traffic Impact Study Contents	65
800.13	Site Plan Review Criteria and Standards	67
800.14	Outside Assistance & Expertise	68
800.15	Changes To Site Plans.....	68
ARTICLE IX SIGNS AND OUTDOOR ADVERTISING STRUCTURES		69
900.01	Statement of Purpose.....	69
900.02	Permits and Fees	69
900.03	Application for Permit	69
900.04	Referral of Application to Design Review Board and Issuance of Permit	69

900.05	Permit Fees	70
900.06	Revocability of Permits	70
900.07	Authority to Revoke	70
900.08	Permit Exemptions	70
900.09	Construction	70
900.10	Wall Signs	71
900.11	Projecting Signs	71
900.12	Ground, Free Standing and Expressway Signs.....	71
900.13	Expressway Signs	71
900.14	Awnings and Canopies.....	72
900.15	Signs in Residential Districts	72
900.16	Signs Prohibited	72
900.17	Maximum Number and Size of Signs Permitted Within each Zoning District	73
900.18	General Provisions	73
900.19	Temporary Signs	74
900.20	Removal of Certain Signs.....	74
900.21	Unsafe and Unlawful Signs	74
900.22	Annual Inspection	74
900.23	Maintenance	75
900.24	Presumption of Responsibility	75
900.25	Nonconforming Existing Signs	75
900.26	Temporary Signs - General	75
900.27	Commercial Temporary Signs.....	75
900.28	Standards for All Temporary Signs	76
900.29	Vending Machines	76
900.30	Nonprofit Promotional Signs.....	76
900.31	LED and Digital Signs.....	76
900.32	Lighting:	77
ARTICLE X	NONCONFORMITIES	78
1000.01	Continuance of Nonconforming Uses	78
1000.02	Expansion or Enlargement of Nonconforming Uses	78
1000.03	Discontinuance of Nonconforming Uses	78
1000.04	Reconstruction of Nonconforming Uses.....	78
1000.05	Nonconforming Mobile Homes.....	78
1000.06	Nonconforming Uses Under Construction.....	78
1000.07	Change of Nonconforming Uses	78
1000.08	Continuance of Nonconforming Structures	79
1000.09	Nonconforming Lots of Record	79
1000.10	Nonconforming Signs	79
ARTICLE X I	ENFORCEMENT	80
1100.01	Zoning Certificates Required.....	80
1100.02	Zoning Certificates For Existing Uses Which May Be Nonconforming.	80
1100.03	Application and Issuance of Zoning Certificates	80
1100.04	Fees for Zoning Certificates	81
1100.05	Zoning Certificate Records.....	81
1100.06	Violations -- Penalties.....	81
1100.07	Remedies	81
1100.08	Zoning Inspector.....	81
ARTICLE XII	PLANNING COMMISSION	83
1200.01	Establishment and Organization of The Planning Commission	83
1200.02	Powers and Duties	83
1200.03	Review of Conditional Uses.....	83
1200.04	Expiration of Conditional Uses	83
1200.05	Hearings & Rules	84

1200.06	Minutes and Records	84
1200.07	Witnesses & Oaths.....	84
1200.08	Notification of Site Plan Review.....	84
ARTICLE XIII BOARD OF ZONING APPEALS		85
1300.01	Establishment & Appointment Of Board of Zoning Appeals Members.....	85
1300.02	Hearings & Rules	85
1300.03	Minutes and Records	85
1300.04	Witnesses & Oaths.....	85
1300.05	Powers and Duties	85
1300.06	Department Assistance	85
1300.07	Applications	86
1300.08	Hearings & Notification.....	86
1300.09	Decisions of the Board	86
1300.10	Appeals Based on Alleged Errors or Matters of Interpretation	86
1300.11	Criteria for Approval of a Change of Nonconforming Uses	86
1300.12	Expiration of Approval to change Nonconforming Uses.....	86
1300.13	Variances	86
1300.14	Requirements to Grant a Variance.....	86
1300.15	Appeals For a Certificate of Appropriateness.....	87
ARTICLE XIV AMENDMENTS.....		88
1400.01	General.....	88
1400.02	Notice and Public Hearing	88
1400.03	Application Fees	88
ARTICLE X VALIDITY AND SEPARABILITY		89
ARTICLE XI EFFECTIVE DATE		90

**ZONING ORDINANCE
ORDINANCE NO. K-5-94-2**

ZONING ORDINANCE OF THE MUNICIPALITY OF NEW CONCORD, OHIO

AN ORDINANCE to amend Ordinance No. K-6-71-1, for the purpose of promoting public health, safety, morals, comfort and general welfare; to conserve and protect property and property values; to secure the most appropriate use of land; and to facilitate adequate but economical provision of public improvements, all according to a comprehensive plan, the municipality of New Concord, Ohio finds it necessary and advisable to regulate the location, height, area, number and size of buildings and other structures, percentages of lot area that may be occupied, size of yards, courts and other open spaces, density of population, uses of buildings and other structures and the uses of land; and for such purposes dividing the area of the municipality into districts and zones of such number, shape and area as are deemed best suited to carry out said purposes, providing a method of administration, and prescribing penalties and proceedings for the administration and enforcement of this Ordinance.

BE IT ORDAINED BY THE COUNCIL OF THE MUNICIPALITY OF NEW CONCORD, OHIO:

ARTICLE I TITLE AND ENACTMENT CLAUSE

100.01 Authority

The Council of New Concord, Ohio in accordance with enabling legislation for municipal zoning as provided in Chapter 713 of the Ohio Revised Code hereby provides as follows:

100.02 Title

This Ordinance shall be known and cited as Ordinance No. K-5-94-1, or as the Zoning Code for New Concord, as amended by Ordinance K-3-96-1.

100.03 Purpose

This Ordinance is adopted in accordance with a comprehensive plan, for the purpose of protecting and promoting the public health, safety, morals, comfort and general welfare; conserving the values of property, facilitating the economical provision of water, sewerage, and other public requirements and lessening or avoiding congestion on public streets and highways.

ARTICLE II

DEFINITIONS

200.01 Definitions

For the purpose of this ordinance certain terms and words are defined as follows. Words used in the present tense include the future, and the plural includes the singular, and the singular the plural. The word "shall" is intended to be mandatory; "occupied" or "used" shall be considered as though followed by the words "or intended, arranged, or designed to be used or occupied." Except where specifically defined, all words used in this ordinance shall carry their customary meanings.

Abutting: Having a common border with, or being separated from such a common border by a right-of-way, alley, or easement.

Accessory Use: A use incidental to, and on the same lot as, a principal use.

Accessory Apartment: A separate and complete dwelling unit that is contained within the structure of a single-family dwelling unit.

Accessory Structure: A subordinate structure detached from but located on the same lot as the principal structure, the use of which is incidental and accessory to that of the principal structure.

Adult Motion Picture Theater: An establishment where, for any form of consideration, films, motion pictures, video cassettes, slides, or similar photographic reproductions are shown, and in which a substantial portion of the total presentation time is devoted to the showing of material characterized by an emphasis on the depiction or description of specified sexual activities or specified anatomical areas.

Adult Cabaret: A nightclub, bar, restaurant, or similar establishment that regularly features live performances that are characterized by the exposure of specified anatomical areas or by specified sexual activities, or films, motion pictures, video cassettes, slides, or other photographic reproductions in which a substantial portion of the total presentation time is devoted to the showing of material that is characterized by an emphasis upon the depiction or description of specified sexual activities or specified anatomical areas.

Adult Bookstore: An establishment that has as a substantial portion of its stock-in-trade and offers for sale, for any form of consideration, any one or more of the following: 1) books, magazines, periodicals, or other printed matter, or photographs, films, motion pictures, video cassettes, slides, or other visual representations that are characterized by an emphasis upon the depiction or description of specified sexual activities or specified anatomical areas; or 2) instruments, devices, or paraphernalia that are designed for use in connection with specified sexual activities.

Agriculture: The use of land for agricultural purposes, including farming, dairying, pasturage agriculture, horticulture, floriculture, viticulture, and animal and poultry husbandry and the necessary accessory uses for packing, treating, or storing the produce; provided, however, that the operation of any such accessory uses shall be secondary to that of normal agricultural activities.

Alley: A public or private way permanently reserved as a secondary means of access to abutting property.

Alteration, Structural: Any change in the supporting members of a building or structure, such as bearing walls columns, beams, or girders: provided, however, that the application of any exterior siding to an existing building for the purpose of beautifying and modernizing shall not be considered a structural alteration.

Alteration: Any change, addition, or modification in construction or occupancy of an existing structure.

Amusement Arcade: A building or part of a building in which five or more pinball machines, video games, or other similar player-operated amusement devices are maintained.

Automobile Sales and Service Businesses: The use of any building or portion thereof, or other premises or portion thereof, for the display, sale, rental, or lease of new motor vehicles, or used motor vehicles, along with any warranty repair work, and other repair service conducted as an accessory use on the same premises.

Automobile Wrecking Yard: (See also junkyard) The dismantling or wrecking of used motor vehicles or trailers, or the storage, sale, or dumping of dismantled or wrecked vehicles or their parts. The presence on any lot or parcel of land of two or more motor vehicles, which, for a period exceeding 30 days, have not been capable of operating under their own power and from which parts have been or are to be removed for reuse or sale, shall constitute prima-facie evidence of an automobile wrecking yard.

Awnings: Any structure made of cloth with a metal frame attached to a building and projecting over a sidewalk, when the same is so erected as to permit its being raised to a position flat against the building when not in use.

Bar or Lounge: Any premises wherein alcoholic beverages are sold at retail for consumption on the premises and minors are excluded there from by law. It shall not mean a premises wherein such beverages are sold in conjunction with the sale of food for consumption on the premises and the sale of said beverages comprises less than 25 percent of the gross receipts.

Basement: That portion of a building that is partly or completely below grade.

Bed and Breakfast: A house, or portion thereof, where short-term lodging rooms and meals are provided. The operator of the inn shall live on the premises or in adjacent premises.

Bedroom: The term bedroom includes any room used principally for sleeping purposes, an all-purpose room, a study, or a den, provided that no room having less than 100 square feet of floor area shall be considered a bedroom.

Billboard: Any structure or portion thereof, situated on private premises, on which lettered, figured or pictorial matter is displayed for advertising purposes, other than the name and occupation of the user of the premises or the nature of the business conducted thereon or the products primarily sold or manufactured thereon. Unless specifically indicated otherwise, billboards shall include any off-premise signs.

Board: The Board of Zoning Appeals of the Municipality of New Concord, Ohio.

Boarding House: An establishment with lodging for five or more persons where meals are regularly served for compensation and where food is placed upon the table family style, without service or ordering of individual portions from a menu. Also includes rooming house and college related clubs.

Buffer Area: (See also screening) A landscaped area intended to separate and partially obstruct the view of two adjacent land uses or properties from one another.

Building Line: The line, parallel to the street line that passes through the point of the principal building nearest the front lot line.

Building Height: The vertical distance to the highest point of the roof for flat roofs; to the deck line of mansard roofs; and to the maximum height of any segment of a hip, gable or gambrel roof, as measured from

the average surrounding grade elevation.

Campground: An area or tract of land on which accommodations for temporary occupancy are located or may be placed, including cabins, tents, and major recreational equipment, and which is primarily used for recreational purposes and retains an open air or natural character.

Canopy: Any structure, other than an awning, made of cloth or metal with a metal frame, attached to a building, projecting over a sidewalk, and carried by a frame supported by the ground or sidewalk.

Car Wash: An area of land and/or a structure with machine or hand-operated facilities used principally for the cleaning, washing, polishing, or waxing of passenger motor vehicles.

Car wash, industrial: Mechanical facilities for the washing, waxing, and vacuuming of heavy trucks and buses and other commercial vehicular equipment.

Cemetery: Land used or intended to be used for the burial of the dead and dedicated for cemetery purposes, including, crematories, mausoleums, and mortuaries when operated in conjunction with and within the boundaries of such cemetery.

Child Care Facility: A building or structure where care, protection, and supervision are provided, on a regular schedule, at least twice a week to at least seven children.

Church or Place of Religious Worship: An institution that people regularly attend to participate in or hold religious services, meetings, and other activities. The term "church" shall not carry a secular connotation and shall include buildings in which the religious services of any denomination are held.

Clinic: A building designed and used for the diagnosis and treatment of human patients that does not include overnight care facilities.

Club: Buildings or facilities owned or operated by a corporation, association, or persons for a social, educational, or recreational purpose; but not primarily for profit or to render a service that is customarily carried on as a business. This does not include student related organizations.

Commercial Recreational Facilities: Recreational facilities open to the public, established and operated for a profit such as commercial golf courses, golf driving ranges, swimming pools, ice skating rinks, riding stables, race tracks, carnivals, boat docks and launching ramps, fishing piers and similar commercial enterprises.

Commission: The Planning Commission of New Concord.

Community Center: A place, structure, area, or other facility used for and providing religious, fraternal, social, and/or recreational programs generally open to the public and designed to accommodate and serve significant segments of the community.

Comprehensive Plan: The long-range plan, and any updates thereto, describing the desirable use of land as adopted by the Planning Commission; the purpose of such plan being, among other purposes, to serve as a guide in future development and zoning for the municipality.

Conditional Use: A use that, owing to some special characteristics attendant to its operation or installation (for example, potential danger, smoke, or noise), is permitted in a district subject to approval by the Board of Zoning Appeals, and subject to special requirements, different from those usual requirements for the district in which the conditional use may be located.

Convenience Store: A small-scale food store usually less than 10,000 square feet in size, generally located

in small neighborhood convenience centers. Such stores may have on-site service of food or drink for immediate consumption, carry for sale general food items as well as medicines, cosmetics, and limited beer and wine items.

Congregate Housing: A residential facility for four or more elderly persons (age 60 or older) within which are provided living and sleeping facilities, meal preparation, laundry services, and room cleaning. Such facilities may also provide other services, such as transportation for routine social and medical appointments, and counseling.

Council: The Village Council of New Concord.

Density: The number of dwelling units permitted per net acre of land (excluding any public right-of-way).

Development: All structures and other modifications of the natural landscape above and below ground or water, on a particular site.

Dormitory: A building or buildings used primarily as living quarters for students or other groups associated with a college, university, club, boarding school, orphanage, convent, monastery, labor camp, religious orders or other similar uses. Dormitories include buildings with or without individual units or apartments.

Drive-in facility: An establishment that, by design of physical facilities or by service or packaging procedures, encourages or permits customers to receive a service or obtain a product that may be used or consumed in a motor vehicle on the premises or to be entertained while remaining in an automobile.

Dry Cleaner: A business that accepts garments to be cleaned, laundered and/or pressed by employee of such business.

Dwelling Unit: One or more rooms physically arranged so as to create an independent housekeeping establishment for occupancy by one family with separate toilets and facilities for cooking and sleeping.

Dwelling, attached: A dwelling which is joined to another dwelling at one or more sides by a party wall or walls. Also, sometimes known as “zero lot line.”

Dwelling, detached: A dwelling that is not attached to any other dwelling, excluding accessory dwellings.

Dwelling, Multiple-Family: A building or portion thereof used for occupancy by three or more families living independently of each other and containing two or more dwelling units.

Dwelling, Single-Family: A building consisting of a single dwelling unit only, separated from other dwelling units by open space.

Dwelling, Two-Family: A building designed exclusively for occupancy by two families living independently of each other.

Dwelling: A building or portion thereof used exclusively for residential purposes, including single-family and multi-family dwellings. The term “dwelling” shall include those involving industrialized units, but not including, mobile homes, manufactured homes, recreational vehicles, hotels, motels, bed and breakfasts, boarding houses, rooming houses, dormitories, congregated housing, group homes for the handicapped or halfway houses.

Easement: The right of a person, government agency, or public utility company to use public or private land owned by another for a specific purpose.

Facade: The exterior wall of a building exposed to public view or that wall viewed by persons not within the building.

Family: One or more persons related by blood, adoption, or marriage, guardianship or foster parent contract living and cooking together as a single housekeeping unit, exclusive of household servants. A number of persons but not exceeding two (2) living and cooking together as a single housekeeping unit though not related by blood, adoption, or marriage shall be deemed to constitute a family.

Fence: Any artificially constructed barrier of any material or combination of materials erected to enclose or screen areas of land.

Frontage: The front or frontage is that side of a lot abutting on a street or way and ordinarily regarded as the front of the lot, but it shall not be considered as the ordinary side line of a corner lot.

Funeral Home: A building or part thereof used for human funeral services. Such building may contain space and facilities for: a) embalming and the performance of other services used in preparation of the dead for burial; b) the performance of autopsies and other surgical procedures; c) the storage of caskets, funeral urns, and other related funeral supplies; and d) the storage of funeral vehicles, but shall not include facilities for cremation. Where a funeral home is permitted, a funeral chapel shall also be permitted.

Garage, Private: A building for the private use of the owner or occupant of a principal building situated on the same lot of the principal building for the storage of motor vehicles with no facilities for mechanical service or repair of a commercial or public nature.

Garage, Repair: A building designed and used for the storage, care, repair, or refinishing of motor vehicles including both minor and major mechanical overhauling, paint, and body work.

Gas Station & Convenience store: A facility associated with the sale of gasoline products that also offers for sale prepackaged food items and tangible consumer goods, primarily for self-service by the consumer. Hot beverages, fountain-type beverages, and pastries may be included in the food items offered for sale.

Grade: The lowest point of elevation of the finished surface of the ground, paving, or sidewalk within the area between the building and the property line, or when the property line is more than five feet from the building, between the building and a line five feet from the building.

Gross Floor Area: The sum of the areas of the several floors of a building, including areas used for human occupancy in basements, attics, and penthouses, as measured from the exterior faces of the walls. It does not include cellars, unenclosed porches, or attics not used for human occupancy, or any floor space in accessory buildings or in the main building intended and designed for the parking of motor vehicles in order to meet the parking requirements of this bylaw, or any such floor space intended and designed for accessory heating and ventilating equipment. It shall include the horizontal area at each floor level devoted to stairwells and elevator shafts.

Group Home for the Handicapped: A dwelling shared by four or more handicapped persons including resident staff, who live together as a single housekeeping unit and in a long-term, family-like environment in which staff persons provide needed care, education, and participation in community activities for the residents with the primary goal of enabling the resident to live as independently as possible in order to reach their maximum potential.

As used herein, the term "handicapped" shall mean having: 1) a physical or mental impairment that substantially limits one or more of such person's major life activities so that such person is incapable of living independently, 2) a record of having such an impairment; or 3) being regarded as having such impairment. However, "handicapped" shall not include current illegal use of or addiction to a controlled substance, nor shall

it include any person whose residency in the home would constitute a direct threat to the health and safety of other individuals. The term "group home for the handicapped" shall not include alcoholism or drug treatment center, work release facilities for convicts or ex-convicts, or other housing facilities serving as an alternative to incarceration.

Halfway House: A licensed home for persons in lieu of such more restrictive custodial confinement, wherein supervision, rehabilitation, and counseling are provided to mainstream residents back into society, enabling them to live independently. Such placement is pursuant to the authority of the State Department of Corrections.

Health Club: A facility where members or nonmembers use equipment or space for the purpose of physical exercise.

Home Occupation, Class 1: An occupation, profession, activity, or use that is clearly a customary, incidental, and secondary use of a residential dwelling unit. A Class 1 home occupation is defined as an activity with the following characteristics:

1. It is conducted entirely within the dwelling and occupies no more than twenty-five (25) percent of the total floor area of the dwelling, or does not exceed five hundred (400) square feet in area.
2. No equipment or processes used in conjunction with the home occupation is audible outside of the residence, or causes interference in any radio or television receivers off the premises.
3. There are no employees related to the home occupation that are not full time residences of the dwelling.
4. All activities related to the home occupation are carried on indoors and no outdoor storage or display shall be permitted.
5. There is no change in the exterior appearance of the dwelling, or other visible evidence of the conduct of such home occupation other than a permitted non-illuminated sign.
6. No traffic is generated by the home occupation in greater volumes than would normally be expected in a residential neighborhood.
7. No article shall be offered for sale on the premises.
8. The home occupation shall not entail the use or storage of explosive, flammable, or otherwise hazardous waste.

Home Occupation, Class 2: An occupation, profession, activity, or use that is clearly a customary, incidental, and secondary use of a residential dwelling unit. A Class 2 home occupation is defined as an activity with the following characteristics:

1. It is conducted entirely within the dwelling and occupies no more than thirty-three (33) percent of the total floor area of the dwelling, or occupies more than fifty (50) percent of an accessory structure (such as a garage).
2. There is no change in the exterior appearance of the dwelling, or other visible evidence of the conduct of such home occupation other than a permitted non-illuminated sign.
3. No equipment or processes used in conjunction with the home occupation is audible outside of the residence, or causes interference in any radio or television receivers off the premises.
4. There are up to two non-residents working as full or part time employees.
5. All activities related to the home occupation are carried on indoors and no outdoor storage or display shall be permitted.
6. Articles are offered for sale on the premises, or services to the public are provided on site (such as sewing, tool sharpening, small engine repair, computer repair, etc.).
7. Off-street parking for customers is provided only in residential driveways (not in dedicated parking areas or lots).
8. The home occupation shall not entail the use or storage of explosive, flammable, or otherwise hazardous waste.

Hospital: An institution specializing in giving clinical, temporary, and emergency services of a medical or surgical nature to human patients and injured persons, and licensed by state law to provide facilities and services in surgery, obstetrics, and general medical practice.

Hotel: A facility offering transient lodging accommodations on a daily rate to the general public and providing additional services, such as restaurants, meeting rooms, and recreational facilities.

Impervious Surface: Any material that substantially reduces or prevents the infiltration of storm water into previously undeveloped land. Impervious surface shall include graveled driveways and parking areas.

Junk: Used machinery, scrap, iron, steel, other ferrous and nonferrous metals, tools, implements or portions thereof, glass, plastic, cordage, building materials, or other waste that has been abandoned from its original use and may be used again in its present or in a new form.

Junkyard (See also automobile wrecking yard): An area where junk, wastes or used or secondhand materials are bought, sold, exchanged, stored, processed, or handled. Materials shall include but are not limited to scrap iron and other metals, paper, rags, rubber tires, and bottles. An automobile wrecking yard is also considered a junkyard.

Kennel: An establishment licensed to operate a facility housing dogs, cats, or other household pets and where grooming, breeding, boarding, training, or selling of animals is conducted as a business.

Kennel, private: Any building or buildings or land designed or arranged for the care of dogs and cats belonging to the owner of the principal use, kept for purposes of show, hunting, or as pets.

Laundry, Self-service: A business that provides home-type washing, drying, and/or ironing machines for hire to be used by customers on the premises.

Lot Line, Side: Any lot line not a front or rear lot line.

Lot Line, Rear: The lot line not intersecting a front lot line that is most distant from and most closely parallel to the front lot line. A lot bounded by only three lot lines will not have a rear lot line.

Lot Line: A line dividing one lot from another lot or from a street or alley.

Lot Width The horizontal distance between side lot lines measured at the required front setback line.

Lot of Record: A lot whose existence, location, and dimensions have been legally recorded or registered in a deed or on a plat.

Lot, Corner: A lot abutting on and at the intersection of two or more streets.

Lot, Interior: An interior lot is a lot other than a corner lot.

Lot Coverage: Determined by dividing that area of a lot that is occupied or covered by the total horizontal projected surface of all buildings, including covered porches and accessory buildings, by the gross area of that lot.

Lot Area: The area of horizontal plane bounded by the vertical planes through front, side, and rear lot lines.

Lot Depth: The average horizontal distance between the front and rear lot lines.

Lot: A parcel of land intended to be separately owned, developed, and otherwise used as a unit.

Manufactured Home Park: A parcel of land under single ownership that has been planned and improved for the placement of manufactured housing for dwelling purposes.

Manufactured Home (See also mobile home): A factory-built, single-family structure that is manufactured under the authority of 42 U.S.C. Sec. 5401, the National Manufactured Home Construction and Safety Standards Act, of 1974, is transportable in one or more sections, is built on a permanent chassis, and is used as a place of human habitation; but which is not constructed with a permanent hitch or other device allowing transport of the unit other than for the purpose of delivery to a permanent site, and which does not have wheels or axles permanently attached to its body or frame.

Mineral Extraction, Storage, and Processing: Any mining, quarrying or processing of limestone, sand, gravel, oil, natural gas, or other mineral resources.

Mobile Home (See also manufactured home): A transportable, factory built home, designed to be used as a year-round residential dwelling and built prior to the enactment of the Federal Manufactured Home Construction and Safety Standards Act of 1974 which became effective June 15, 1976.

Mobile Retail Food Establishment Court: retail food establishments, grouped together, that are readily moveable, are motorized wheeled vehicles, or towed wheeled vehicles, designed and equipped to serve food. Shall include both "hot trucks" upon which food is cooked and prepared for vending, and "cold trucks" from which only commissary - prepared, ready - to eat or packaged foods in individual servings are handled. Also referred to as a food truck and/or trailer court.

Motel (See also hotel): A building or group of detached or connected buildings designed or used primarily for providing sleeping accommodations for automobile travelers and having a parking space next to a sleeping room. An automobile court or a tourist court with more than one unit or a motor lodge shall be deemed a motel.

Nonconforming Use: A lawful use of land that does not comply with the use regulations for its zoning district.

Nonconforming Lot: A lot that does not meet the requirements of this Zoning Ordinance due to size and/or other lot dimension.

Nonconforming Building: Any building that does not meet the limitations on building size and location on a lot, for the district in which such building is located, for the use to which such building is being put.

Office: A building or portion of a building wherein services are performed involving predominantly administrative, professional, or clerical operations.

Open Space: An area that is intended to provide light and air, and is designed for either environmental, scenic, or recreational purposes. Open space may include, but is not limited to, lawns, decorative planting, walkways, active and passive recreation areas, playgrounds, fountains, swimming pools, wooded areas, and water courses. Open space shall not be deemed to include driveways, parking lots, or other surfaces designed or intended for vehicular travel.

Outdoor Furnaces: Any fuel burning equipment, apparatus, or structure located outside of a primary structure used to heat or supplement the heating of a structure.

Outdoor storage: The keeping, in an unroofed area, of any goods, junk, material, merchandise, or vehicles in the same place for more than 72 hours.

Parcel: A continuous quantity of land in the possession of or owned by, or recorded as the property of, the

same person or persons.

Parking Space: An area on a lot and/or within a building intended for the use of temporary parking of a personal vehicle. This term is used interchangeably with parking stall. Each parking space must have a means of access to a public street. Tandem parking stalls in single-family detached, single-family attached, and townhome residential uses shall be considered to have a means of access to a public street.

Parking Lot (See also garage, public): An area not within a building where motor vehicles may be stored for the purposes of temporary, daily, or overnight off-street parking.

Planned Unit Development: Land under unified control to be planned and developed as a whole in a single development operation or a definitely programmed series of development operations or phases. A planned unit development includes principal and accessory structures and uses substantially related to the character and purposes of the planned development. A planned development is built according to general and detailed plans that include not only streets, utilities, lots and building location, and the like, but also site plans for all buildings as are intended to be located, constructed, used, and related to each other, and plans for other uses and improvements on the land as related to the buildings. A planned development includes a program for the provisions, operations, and maintenance of such areas, facilities, and improvements as will be for common use by some or all of the occupants of the planned development district, but which will not be provided, operated, or maintained at general public expense.

Plant Nursery: The cultivation of crops, fruit trees, nursery stock, truck garden products and similar plant materials outside or within greenhouses for sale or for transplanting.

Principal Use: The main use of land or structures, as distinguished from a secondary or accessory use.

Principal Building: A building in which the primary use of the lot on which the building is located is conducted.

Print Shop: A retail establishment that provides duplicating services using photocopy, blueprint, and offset printing equipment, including collating of booklets and reports.

Public Service Facility: The erection, construction, alteration, operation or maintenance of buildings, power plants or substations, water treatment plants or pumping stations, sewage disposal or pumping plants and other similar public service structures by a public utility, by a railroad, whether publicly or privately owned, or by a municipal or other governmental agency, including the furnishing of electrical, gas, rail transport, communication, public water and sewerage services.

Recreational Vehicle: A vehicular-type unit primarily designed as temporary living quarters for recreational, camping, or travel use, which either has its own motive power or is mounted on or drawn by another vehicle.

Recreational Vehicle Park: A parcel of land reserved for the location of recreational vehicles, including buildings and sites set aside for group camping and similar recreational vehicles.

Recycling Center: A facility that is not a junkyard and in which recoverable resources, such as newspapers, glassware, and metal cans, are collected, stored, flattened, crushed, or bundled, essentially by hand within a completely enclosed building.

Research Laboratory: A building or group of buildings in which are located facilities for scientific research, investigation, testing, or experimentation, but not facilities for the manufacture or sale of products, except as incidental to the main purpose of the laboratory.

Restaurant: An establishment that serves food and beverages primarily to persons seated within the building.

This includes cafes, tea rooms, and outdoor cafes.

Right-of-way: An area or strip of land, either public or private, on which an irrevocable right-of-passage has been recorded for the use of vehicles or pedestrians or both.

Road, Public: All public property reserved or dedicated for street traffic.

Rooming House: A building that is a primary residence of the owner and in which rooms are provided by the owner, for compensation, to three or more adult persons not related by blood, marriage or adoption guardianship or foster parent contract to the owner. A building that is the residence of three or more persons not related by blood, adoption, or marriage guardianship or foster parent contract containing one or more rooms intended for use for living or sleeping in which space is let for compensation in any form by the owner. A rooming house may include common cooking, bathroom, toilet, laundry and/or eating facilities not located within the rooming unit. Rooming house may include housing for students and fraternity and sorority houses, but shall not include a hotel, bed and breakfast, boarding house, congregate housing, group home for the handicapped, or dormitory.

Satellite Dish Antenna: A device incorporating a reflective surface that is solid, open mesh, or bar configured and is in the shape of a shallow dish, cone, horn, or cornucopia. Such device is used to transmit and/or receive radio or electromagnetic waves between terrestrially and/or orbitally based uses. This definition is meant to include but not be limited to what are commonly called satellite earth stations, television reception only satellite dish antennas (TVROs), and satellite microwave antennas.

School: A facility that provides a curriculum of elementary and secondary academic instruction, including kindergartens, elementary schools, junior high schools, and high schools.

Screening (See also buffer yard): The method by which a view of one site from another adjacent site is shielded, concealed, or hidden. Screening techniques include fences, walls, hedges, berms, or other features.

Seating Capacity: The actual seating capacity of an area based upon the number of seats or one seat per 18 inches of bench or pew length.

Self-Service Storage Facility: A building consisting of individual, small, self-contained units that are leased or owned for the storage of business and household goods or contractors supplies.

Self-Service Laundry: A business that provides home-type washing, drying, and/or ironing machine for hire to be used by customers on the premises.

Service Station (See also garage, repair): Any premises where gasoline and other petroleum products are sold and/or light maintenance activities such as engine tune-ups, lubrication, minor repairs, and carburetor cleaning are conducted. Service stations shall not include premises where heavy automobile maintenance activities such as engine overhauls, automobile painting, and body fender work are conducted.

Setback(s): The required minimum horizontal distance between the building line and the related front, side, or rear property line.

Sexually-Oriented Business: An establishment where a substantial portion of the use is related to adult materials, visual representations, performances, or services characterized by an emphasis upon specified sexual activities or specified sexual anatomical areas, including an: adult arcade, adult bookstore, adult cabaret, adult motel, adult motion picture theater, escort agency, nude model studio, massage parlor, sexual encounter center, or sexually-oriented spa.

Sexually-Oriented Spa: A place or structure that provides bathing, saunas, showers or hot tubs, and

engages in or offers to engage patrons in specified sexual activities or activities commonly associated with a sexual encounter center, for any form of consideration.

Specified Sexual Anatomical Areas: Completely and opaquely covered human: genitals; pubic region; vulva; buttocks; anus; anal cleft; or human male genitals in a discernible turgid state even if completely and opaquely covered. The showing of the lower portion of the female breast below a horizontal line across the top of the areola at its highest point, but not including any portion of the cleavage of the human female breast exhibited by a dress, blouse, skirt, leotard, bath suit, or other wearing apparel provided the areola or nipple is not exposed in whole or in part.

Sign, Ground: A free standing detached sign that has a support structure imbedded in the ground, and does not involve any upright poles, or columns for support

Sign, Projecting: Any sign other than a wall sign that is attached to and projects from the wall or face of a building or structure, including an arcade/marquee sign.

Sign, Portable: Any sign not permanently affixed to the ground or to a building, including any sign attached to or displayed on a vehicle that is used for the expressed purpose of advertising a business establishment, product, service, or entertainment, when that vehicle is so parked as to attract the attention of the motoring or pedestrian traffic.

Sign, Roof: Any sign erected upon, against, or directly above a roof or roof eave, or on top or above the parapet, or on a functional architectural appendage above the roof or roof eave.

Sign, Temporary: A display, informational sign, banner, or other advertising device constructed of cloth, canvas, fabric, wood, or other temporary material, with or without a structural frame, and intended for a limited period of display, including decorative displays for holidays or public demonstrations, real estate for sale signs located on the property for sale.

Sign, Window: A sign painted, stenciled, or affixed on a window, which is visible from a right-of-way.

Sign, Wall: A sign painted on the outside of a building, or attached to, and placed parallel to the face of a building and supported by such building.

Sign, Illuminated: A sign illuminated in any manner by an artificial light source.

Sign, Awning, Canopy, or Marquee: A sign painted, stamped, perforated, or stitched, or otherwise applied on the valance of an awning.

Sign Area: The entire area within a continuous perimeter, enclosing the extreme limits of sign display, including any frame or border. Curved, spherical, or any other shaped sign face shall be computed on the basis of actual surface area. The copy of signs composed of individual letters, numerals, or other devices shall be the sum of the area of the smallest rectangle or other geometric figure encompassing each of said letter or devices. The calculation for a double-faced sign shall be the area of one face only.

Sign, Free Standing: A sign supported by one or more upright poles, columns, or braces placed in or on the ground and not attached to any building or structure.

Sign, Billboard: See billboard.

Sign, Electronic Message Board: Any sign that uses changing lights to form a sign message or messages wherein the sequence of messages and the rate of change is electronically programmed and can be modified by electronic processes.

Sign, Flashing: Any sign, which, by method or manner of illumination, flashes on or off, winks, or blinks with varying light intensity, shows motion, or creates the illusion of motion or revolves in a manner to create the illusion of being on or off.

Sign: Any device or visual communication that is used for the purpose of bringing the subject thereof to the attention of the public through symbols, characters, or letters.

Signable Wall Area: A continuous portion of a building unbroken by doors or windows on any one face of the building. It is calculated by drawing a rectangle within the area and computing the square footage of the rectangle.

Site Plan: A plan, prepared to scale, showing accurately and with complete dimensioning, the boundaries of a site and the location of all buildings, structures, uses, and principal site development features proposed for a specific parcel of land.

Solar Collection System, Roof Mounted: Panels or other solar energy devices which the primary purpose of which is to provide for the collection, inversion, storage, and distribution of solar energy for electricity generation, space heating, space cooling or water heating to buildings on the same property. Roof Mounted Solar Collection System shall be attached to structures and meet the conditions listed herein.

Solar Collection System, Free Standing: Panels or other solar energy devices which the primary purpose of which is to provide for the collection, inversion, storage, and distribution of solar energy for electricity generation, space heating, space cooling or water heating to buildings on the same property and meet the conditions listed herein.

Story: That portion of a building included between the surface of any floor and the surface of the floor next above it, or if there be no floor above it, the space between such floor and the ceiling above it.

Street: A public or private thoroughfare used, or intended to be used, for passage or travel by motor vehicles.

Temporary Building: A structure erected to provide shelter for a use which is temporary in nature.

Truck Terminal: Land and buildings used as a relay station for the transfer of a load from one vehicle to another or one party to another. The terminal cannot be used for permanent or long-term accessory storage for principal land uses at other locations. The terminal facility may include storage areas for trucks and buildings or areas for the repair of trucks associated with the terminal.

Variance: A dispensation permitted on individual parcels of property as a method of alleviating unnecessary hardship by allowing a reasonable deviation from the dimensional (i.e., height, bulk, yard) requirements of this ordinance because of unusual or unique circumstances.

Warehouse: A building used primarily for the storage of goods and materials.

Warehousing and Distribution: A use engaged in storage, wholesale, and distribution of manufactured products, supplies, and equipment, but excluding bulk storage of materials that are inflammable or explosive or that create hazardous or commonly recognized offensive conditions.

Yard, Side: A yard lying between the side lot line of the lot and the nearest line of the building and extending from the front yard to the rear yard, or in the absence of either of such front or rear yards, to the front or rear lot lines.

Yard, Rear: A yard extending across the full width of the lot and lying between the rear lot line and the

nearest line of the building. Rear yard depth shall be measured at right angles to the rear line of the lot.

Yard, Front: A yard extending along the full width of a front lot line between side lot lines and from the front lot line to the front building line in depth.

Yard: The required open space on a lot adjoining a lot line.

ARTICLE III GENERAL PROVISIONS

300.01 Establishment of Districts

The municipality is hereby divided into zoning districts which regulate the general location of structures and use of land. These zoning districts are:

S-1	Open Space and Conservation District
R-1	Suburban Single Family Residential District
R-2	Medium Density Single Family Residential District
R-3	Multi-Family Residential District
O-1	Office-Institutional District
B-1	Local Business District
B-2	Central Business District
B-3	Highway Business District
I-1	General Industrial District
PUD	Planned Unit Development District

In addition to these zoning districts, there are two overlay zoning districts which impose additional zoning requirements unique areas of the Village. These overlay districts are:

ARD	Architectural Review District
TC	Transportation Corridor Overlay District

300.02 Zoning District Map

The boundaries of the zoning districts are shown upon a map which is made a part of this ordinance by Ordinance K-3-96-1. This map is designated as the "Zoning District Map of New Concord, Ohio." This official map is on file with the Clerk.

300.03 Zoning District Boundaries

The district boundary lines on said zoning district map are intended to follow center lines of thoroughfares and railroads or lot lines. In the case of unsubdivided property, the district boundary lines shall be determined by measuring or by indicated dimensions.

300.04 Compliance with Regulations

The regulations set forth by this ordinance within each district shall be minimum requirements and shall apply uniformly to each class or kind of structure or land except as hereinafter provided:

No building, structure or land shall hereafter be used or occupied, and no building or structure or part thereof shall hereafter be erected, constructed, reconstructed, moved or structurally altered, unless in conformity with all of the regulations herein specified for the district in which it is located.

No yard or lot existing at the time of passage of this Ordinance shall be reduced in dimension or area below the minimum requirements set forth herein. Yards or lots created after the effective date of this ordinance shall meet at least the minimum requirements established by this ordinance.

300.05 Interpretation and Conflict

The provisions of this ordinance shall be held to be the minimum requirements for the promotion of the public safety, health, convenience, comfort, morals, prosperity and general welfare. It is not intended by this ordinance to interfere with or abrogate or annul any ordinance, rules, regulations or permits previously adopted

or issued, and not in conflict with any of the provisions of this ordinance, or which shall be adopted or issued, pursuant to law relating to the use of buildings or premises and likewise not in conflict with this ordinance; nor is it intended by this ordinance to interfere with or abrogate or annul any easements, covenants, or other agreements between parties; provided, however, that where this ordinance imposes a greater restriction upon the use of buildings or premises or upon the height of buildings, or requires larger open spaces or larger lot areas than are imposed or required by such other ordinances or agreements, the provisions of this ordinance shall control.

ARTICLE IV DISTRICT USE REGULATIONS AND DEVELOPMENT STANDARDS

400.01 S-1 Open Space & Conservation District

An open space and conservation district is hereby established to protect unique natural and environmentally significant areas such as flood plains and wetlands, and to provide for the open space needs of the community.

400.02 R-1 Suburban Single Family Residential District

The suburban single family residential district is hereby established to provide areas for very low density residential development to provide a quiet place for families where yards are wide, spaces open, people few, and motor vehicles restricted. To provide an atmosphere where family values, youth values and the blessings of quiet seclusions and clean air make the area a sanctuary for people and safe for children. To preserve and protect the character of single family neighborhoods in order to keep these residential protect areas free of overcrowding, disturbing noises, increased traffic, the hazard of moving and parked automobiles, to provide children quiet and open spaces for play and to promote overall quality of life within village boundaries.

400.03 R-2 Medium Density Residential District

The suburban single family residential district is hereby established to provide areas for medium density residential development to provide a quiet place for families where there are yards, open spaces, few people, and motor vehicles are restricted. To provide an atmosphere where family values, youth values and the blessings of quiet seclusions and clean air make the area a sanctuary for people and safe for children. To preserve and protect the character of single family neighborhoods in order to keep these residential protect areas free of overcrowding, disturbing noises, increased traffic, the hazard of moving and parked automobiles, to provide children quiet and open spaces for play and to promote overall quality of life within village boundaries.

400.04 R-3 Multi-Family Residential District

The multi-family residential district is hereby established to provide areas for higher density multi-family residential development and more intense residential uses. The objective is to provide for multi-family developments in areas best equipped to accommodate higher density developments, more vehicles and higher traffic volumes and locate them in areas with adequate access to community services and main thoroughfares, and effectively integrate them into the area and transition them into lower density neighborhoods with less intense residential uses by location and function consistent with those existing in the area.

400.05 O-I Office-Institutional District

The Office-Institutional district is hereby established to provide, at suitable locations, areas where university related institutional land uses and other compatible activities such as offices may be developed and re-developed.

400.06 B-1 Local Business District

The local business district is hereby established to provide, at suitable locations, area where commercial development and some appropriate regional commercial business may also be developed. Except for

hospitals, clinics, veterinary clinics, hotels and motels, no use shall be open for on-site customer business between midnight and 6:00 a.m.

400.07 B-2 Central Business District

The Central Business district is hereby established to encourage appropriate and compatible commercial development in the downtown area of New Concord.

400.08 B-3 Highway Business District

The Central Business district is hereby established to encourage compatible commercial development in certain areas along major thoroughfares.

400.09 I-1 General Industrial District

The General Industrial district is hereby established to provide suitable areas for more intensive industrial development.

400.10 Use Regulations – S-1 through I-1

X= Permitted Use, C= Conditional Use

Land Uses	S-1 Open Space & Conser.	R-1 Suburban Single Family Res.	R-2 Medium Density Res.	R-3 Multi-Family Res.	O-1 Office-Institut.	B-1 Local Business	B-2 Central Business	B-3 Highway Business	I-1 General Industrial
Open Space Uses									
Agriculture	X								X
Campground	X								
Cemetery	C	C							
Commercial Recreational Facility	C								
Forestry	X								
Mineral Extraction, Storage and Processing	C								
Non-commercial Recreational Facility	X								
Plant Nursery	X								
Public Service Facility	X	X	X	X	X	X	X	X	X
Public Parks, Playgrounds or Playing Field	X	X	X	X	X	X	X	X	X
Recreational Vehicle Park	C								
Residential Uses									
Accessory Apartment			C						

Land Uses	S-1 Open Space & Conser.	R-1 Suburban Single Family Res.	R-2 Medium Density Res.	R-3 Multi-Family Res.	O-1 Office-Institut.	B-1 Local Business	B-2 Central Business	B-3 Highway Business	I-1 General Industrial
Bed and Breakfast		C	C	C	X	X	X	X	X
Boarding House				X					
Congregate Housing				X					
Dormitory				C					
Dwellings, in a mixed use building				X			X		
Group Home for the Handicapped				C	C				
Halfway House				C	C				
Manufactured Home Park				C					
Multiple-Family dwellings				X	C	C			
Single-family dwelling, detached		X	X	X	X				
Single-family dwelling, attached				X	X				
Rooming House				X					
Two-family dwellings				X					
Office and Institutional Uses									
Banks and Other Financial Institutions – (without a drive in or drive through feature)						X	X	X	
Banks and Other Financial Institutions – (with a drive in or drive through feature)						C	C	X	
Churches or Places of Religious Worship.		C	C	C	X	X	X	X	X
Club		C	C	C	X	X	X	X	X
College Lecture Hall, Library, Office, Dormitory					X				
Commercial offices, including administrative and sales offices.					X	X		X	
Community Center					X	X	X		
Hospital					X		X	X	

Land Uses	S-1 Open Space & Conser.	R-1 Suburban Single Family Res.	R-2 Medium Density Res.	R-3 Multi-Family Res.	O-1 Office-Institut.	B-1 Local Business	B-2 Central Business	B-3 Highway Business	I-1 General Industrial
Library, Museum, Art Gallery					X	X	X	X	
Nursing Home				X	X	X	X	X	
Professional offices and activities of a professional nature including financial services, doctors' and dentists' offices, etc.					X	X	X	X	X
Research Laboratory					X			X	X
School		X							
Commercial Uses									
Animal hospitals and veterinary offices where there are no outside runs or kennels.								X	X
Antique Store						C	X		
Amusement Arcade								C	
Automobile sales and service businesses including used car lots and repair garages.								C	X
Automobile repair garages								X	X
Bakery						X	X	X	
Bars, cocktail lounges, wine bars, microbrewery							X	X	
Bicycle Sales and Repair						X	X	X	
Building material sales and contractors' offices with outside storage and display								C	X
Building material sales and contractors' offices if conducted wholly within an enclosed building.							X	X	X
Car Wash								X	X

Land Uses	S-1 Open Space & Conser.	R-1 Suburban Single Family Res.	R-2 Medium Density Res.	R-3 Multi-Family Res.	O-1 Office-Institut.	B-1 Local Business	B-2 Central Business	B-3 Highway Business	I-1 General Industrial
Car wash, industrial:									X
Cabinet shop conducted wholly within an enclosed building.							X	X	X
Child Care Facility			C	C	C	C	C	X	
Clothing or Apparel Store						X	X	X	
Coffee shops					C	X	X	X	X
Commercial recreation businesses including bowling alleys, miniature golf courses, etc.							C	X	
Convenience store (without gasoline sales)							X	X	
Copy / Business Center, Print Shop or Printer.						C	X	X	X
Cultural Centers and Museums							X		
Dance or Music Academy						C	X	X	
Entertainment Facility, Commercial							X	X	
Florist						X	X	X	
Fruit, Vegetable, Meat Market						X	X		
Funeral homes.				C	X	X	X	X	X
Gas Station & Convenience Store						C	X	X	
Grocery Store (less than 25,000 square feet)						X	X	X	
Grocery Store (25,000 square feet in size or greater) and supermarkets.								X	
Hardware Stores							X	X	
Health Clubs								X	
Hotels						C	X	X	
Hotels, Extended Stay							X	X	

Land Uses	S-1 Open Space & Conser.	R-1 Suburban Single Family Res.	R-2 Medium Density Res.	R-3 Multi-Family Res.	O-1 Office-Institut.	B-1 Local Business	B-2 Central Business	B-3 Highway Business	I-1 General Industrial
Kennels, animal hospitals and veterinary offices.						C	X	X	X
Kennels, Private		C	C						
Lodges and fraternal organizations.							X		X
Mobile Retail Food Establishment Court							C		
Mobile home and travel trailer sales and service.								X	X
Monument works having retail outlet on premises.								C	X
Motels							C	X	
Repair services and businesses (non-vehicular)						C	X	X	X
Restaurant, without drive through or drive in features.						X	X	X	X
Restaurants with drive-through or drive in service								X	
Retail Sales of General Merchandise						X	X	X	
Retail Sale of Boats or RV's								C	X
Sidewalk Café						X	X	X	
Personal service businesses including barber shops, beauty parlors, and shoe repair shops, laundry and dry cleaning pick-up stations, photography studios and similar businesses.						X	X	X	X
Pharmacy						X	X	X	
Industrial Uses									
Automobile Wrecking Yard									C

Land Uses	S-1 Open Space & Conser.	R-1 Suburban Single Family Res.	R-2 Medium Density Res.	R-3 Multi-Family Res.	O-1 Office-Institut.	B-1 Local Business	B-2 Central Business	B-3 Highway Business	I-1 General Industrial
Asphalt or cement mixing plant.									C
Automobile, Truck or other vehicle repair garages without outdoor storage of materials or items being repaired.						C	C	C	
Automobile, Truck or other vehicle repair garages that involve outdoor storage of materials or items being repaired.								C	X
Billboards.									X
Bottling works.									X
Bulk storage of petroleum products.									C
Carpenter or cabinet workshop									X
Carting, express or hauling establishments.								C	X
Cement or cinder block manufacture.									C
Commercial dry cleaning plants.									
Contractors' establishments and construction equipment dealers.								C	X
Design and development of computer hardware and software, data communications, information technology, data processing, and other computer-related services.								C	X

Land Uses	S-1 Open Space & Conser.	R-1 Suburban Single Family Res.	R-2 Medium Density Res.	R-3 Multi-Family Res.	O-1 Office-Institut.	B-1 Local Business	B-2 Central Business	B-3 Highway Business	I-1 General Industrial
Distribution Facilities and distributors warehouses and wholesale outlets with no outdoor storage, and no processing or fabrication.								C	X
Farm Implement Sale and Storage								C	X
Industrial plants that involve the manufacturing, assembling or production of; small metal products; clothing; drugs and medicines; electrical equipment; glass products; furniture; other wood products; plastic products or finished equipment.									X
Iron, steel, brass or copper foundry.									X
Junkyard									X
Kennels, animal hospitals and veterinary offices.					C	C	X	X	X
Kennels, Private		C	C						
Life science technology and medical laboratories.								X	

Land Uses	S-1 Open Space & Conser.	R-1 Suburban Single Family Res.	R-2 Medium Density Res.	R-3 Multi-Family Res.	O-1 Office-Institut.	B-1 Local Business	B-2 Central Business	B-3 Highway Business	I-1 General Industrial
Limited light manufacturing of small electrical components and related research & development where all processing, fabricating or assembly takes place wholly within an enclosed building.								X	X
Machine Shop									X
Metal stamping.									X
Mineral Extraction, Storage and Processing									X
Paper manufacture.									X
Plant nurseries and greenhouses.						C		X	X
Pressurized Gas Storage and Distribution									C
Printing plants.									X
Radio and television broadcasting stations and towers.									X
Recycling Center								C	X
Research, design, engineering, testing and diagnostics services.								X	X
Storage or Processing of Petroleum Products									C
Utilities, including railroad terminal facilities.								C	X
Warehouses (10,000 square foot or less).								C	X
Warehouses (greater than 10,000 square feet)									X

Land Uses	S-1 Open Space & Conser.	R-1 Suburban Single Family Res.	R-2 Medium Density Res.	R-3 Multi-Family Res.	O-1 Office-Institut.	B-1 Local Business	B-2 Central Business	B-3 Highway Business	I-1 General Industrial
Self- Service Storage Facility								C	X
Sexually-Oriented Business									C
Truck Terminals								C	X
Other Uses									
Accessory Use	X	X	X	X	X	X	X	X	X
Commercial parking lots and garages.						C	C	X	X
Free Standing Solar Collection Systems (less than 25,000 square feet in total area)					X			X	X
Free Standing Solar Collection Systems (more than 25,000 square feet in total area but less than 50,000 square feet in total area)					C			C	
Free Standing Solar Collection Systems (more than 25,000 Sq. Ft., but less than 100,000 square feet – See Section 600.28)								C	C
Wind Turbines								C	
Home Occupations Class 1		X	X	X	X	X	X		X
Home Occupations Class 2		C	C	C	C	C	C		
Parks, playgrounds and community buildings owned or operated by public agencies.	X	X	X	X	X	X	X	X	X
Roof Mounted Solar Collection System (Accessory Use – See Section 600.25)	X	X	X	X	X	X	X	X	X
Off-Street Parking, as required by Article VI	X	X	X	X	X	X	X	X	X
Outdoor storage (subject to 500.17)					C	C	C	C	

400.11 Development Standards – Lots and Principal Buildings

All lots and principal buildings shall meet the following development standards ⁽¹⁾

Zoning District	Min. Lot Size	Min. Lot Frontage	Min. Front Yard	Min. Rear Yard	Min. Side Yard (ea.)	Max. Lot Coverage	Max. Bldg. Height
S-1 Open Space & Conservation	1 Acre	100 feet	60 feet	60 feet	25 feet	40%	45 feet
R-1 Suburban Single Family Residential District	21,780 Sq. Ft.	100 feet	60 feet	60 feet	20 feet	20%	45 feet
R-2 Medium Density Residential District	7,800 Sq. Ft.	65 feet	30 feet	30 feet	6 feet	25%	45 feet
R-3 Multi-Family Residential District	4,500 Sq. Ft.	70 feet	30 feet	30 feet	6 feet	25%	45 feet
O-1 Office-Institutional District	NA	NA	30 feet	30 feet	6 feet	25%	25%
B-1 Local Business District	NA	NA	40 feet	20 feet	6 feet	35%	45 feet
B-2 Central Business District	NA	NA	0 ⁽²⁾	20 feet	NA	NA	45 feet
B-3 Highway Business District	NA	NA	60 feet	20 feet	20 feet	35%	60 feet
I-1 General Industrial District	NA	NA	50 feet	40 feet	20 feet	35%	45 feet

⁽¹⁾ See Article 5 for adjustments to required yard dimensions

⁽²⁾ No front yard is required AND, no building may be located more than twelve feet from the right of way line.

Minimum Lot Size Illustrations

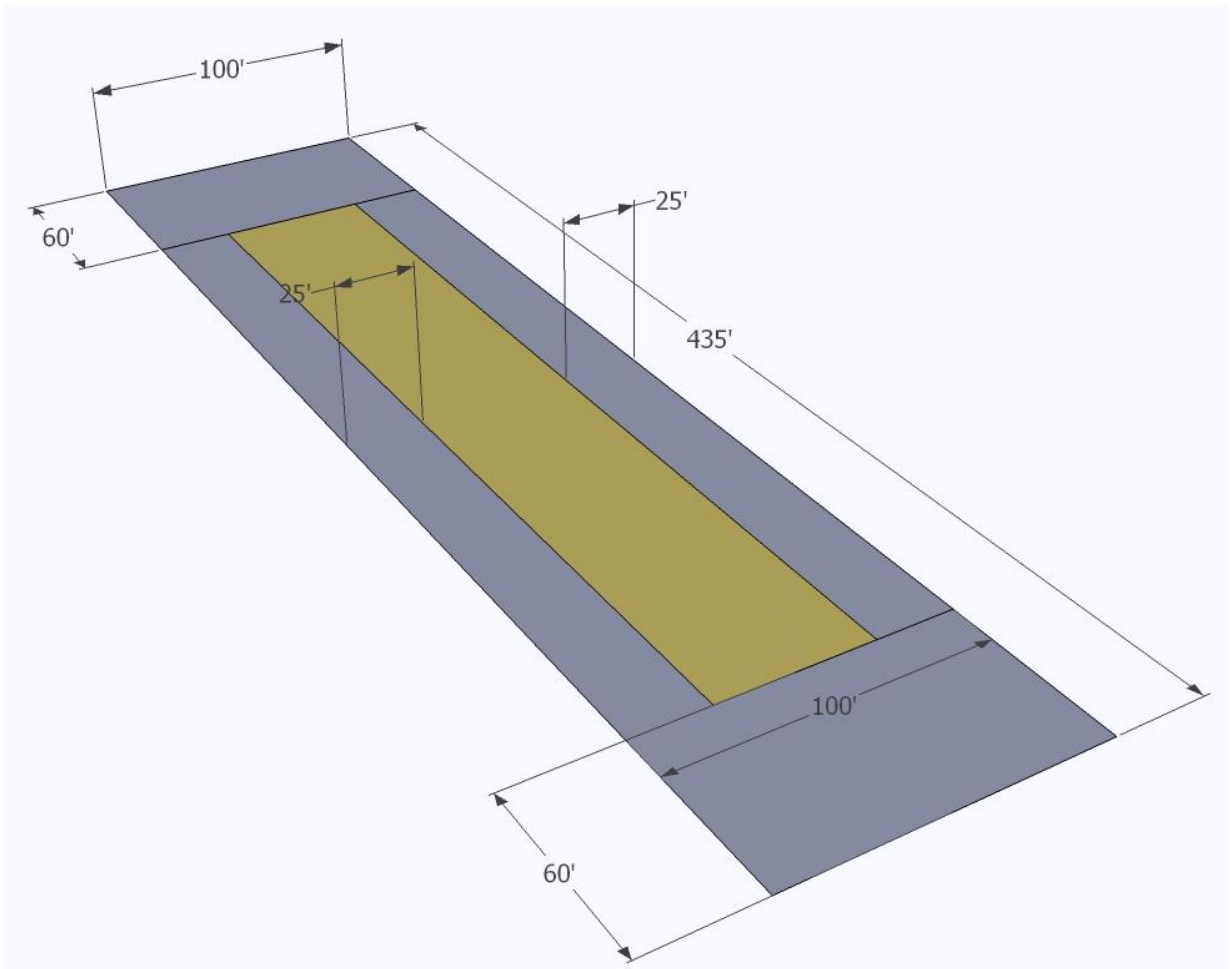

Illustration of S-1 Minimum Lot Standards

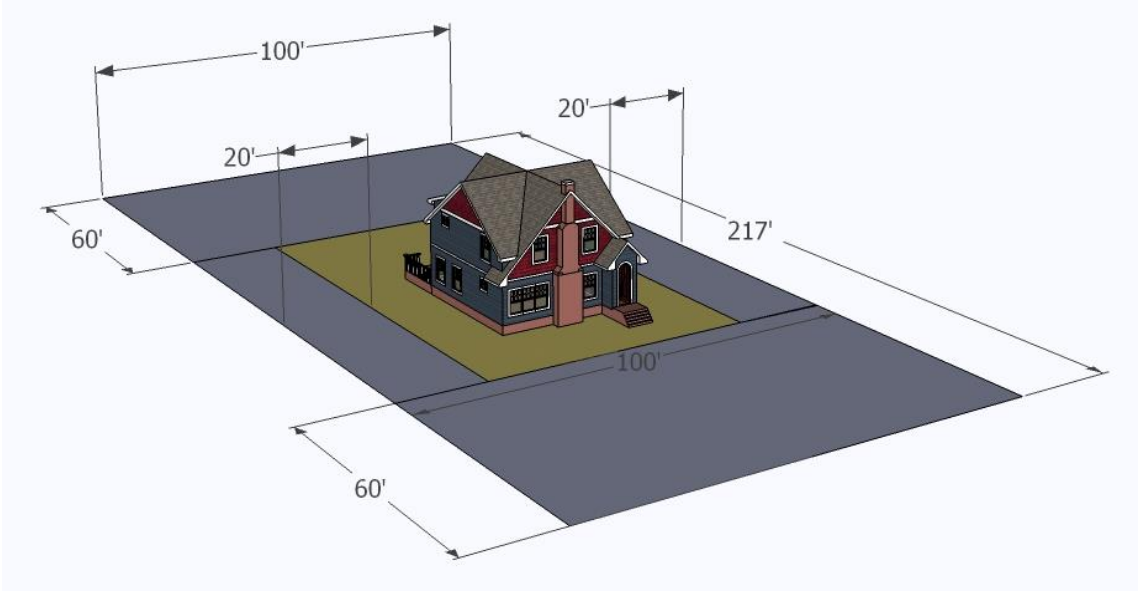

Illustration of R-1 Minimum Lot Standards

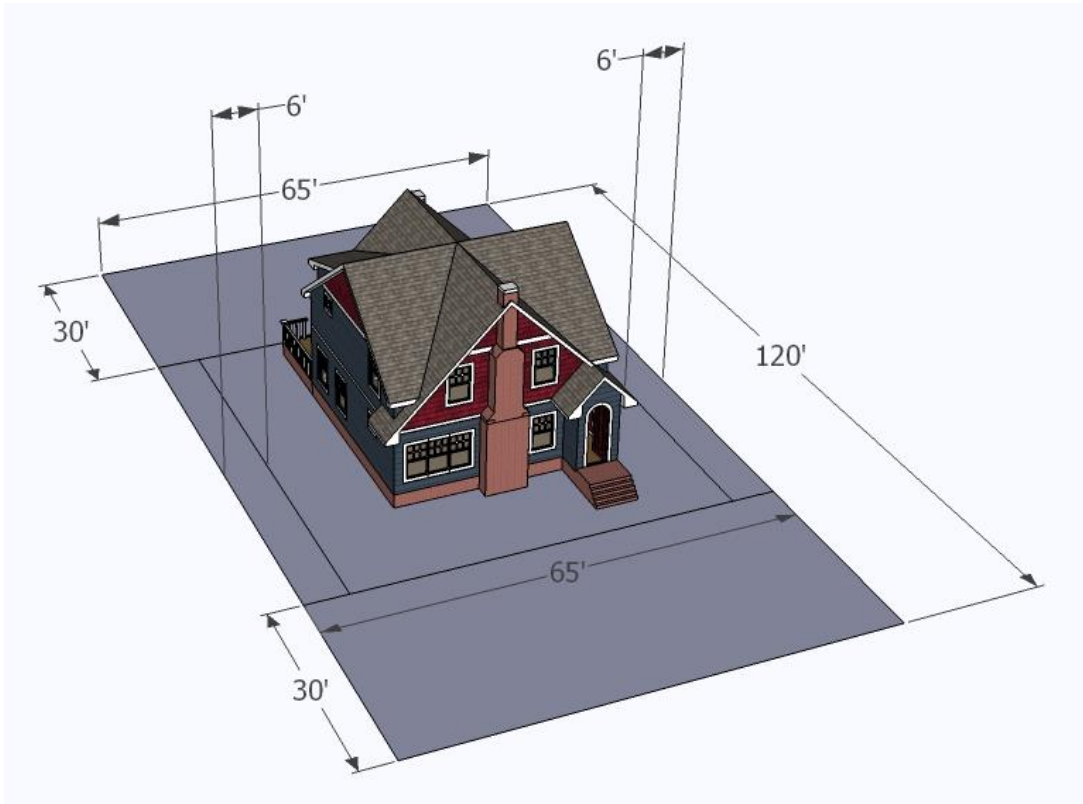

Illustration of R-2 Minimum Lot Standards

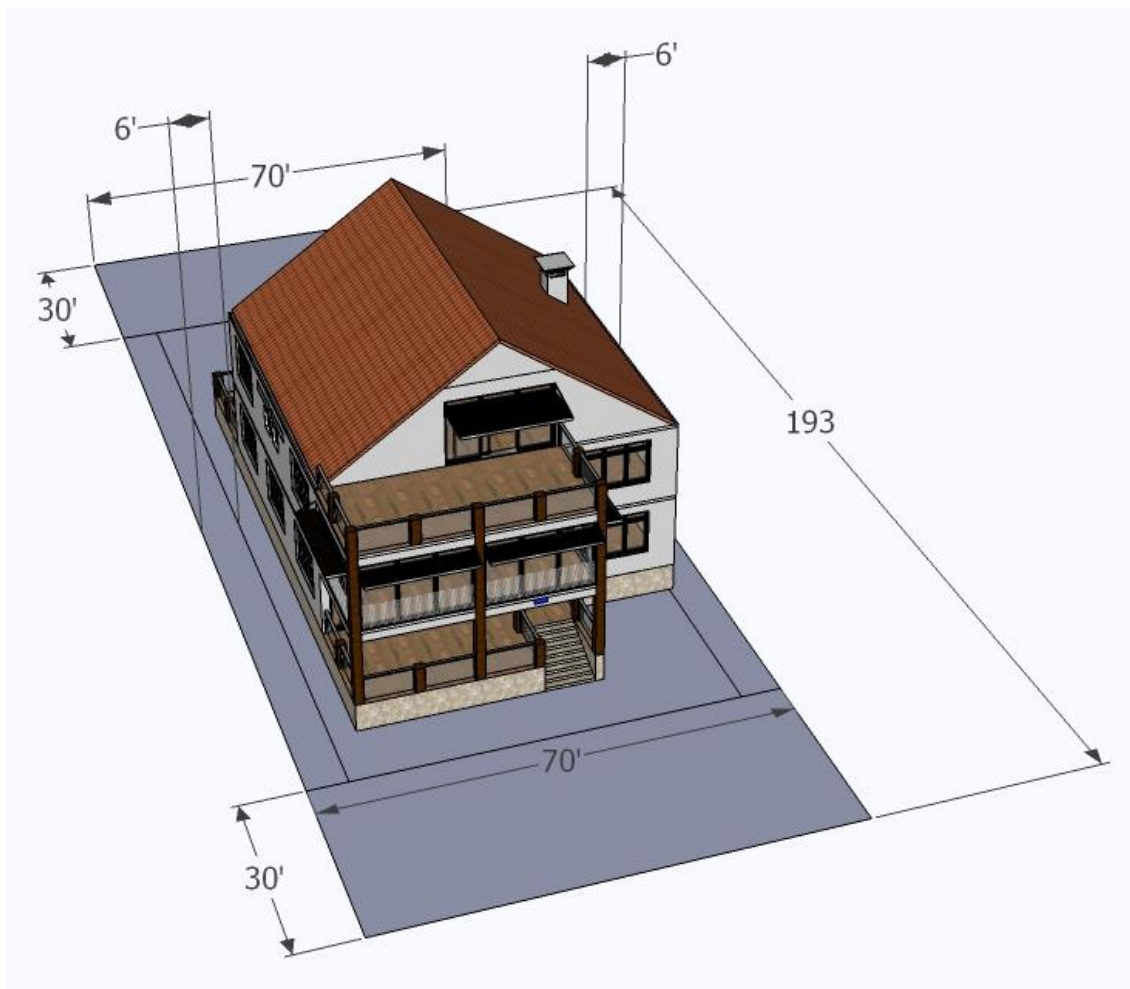

Illustration of R-3 Minimum Lot Standards (3-unit Building Shown)

400.12 Development Standards – Accessory Buildings

All accessory buildings shall meet the following development standards

Zoning District	Development Standards
S-1 Open Space & Conservation	Accessory structures must be located more than five feet from any property line, and may not be located within a required front yard. Detached accessory structures may not occupy more than ten percent of the lot.
R-1 Suburban Single Family Residential District	
R-2 Medium Density Residential District	
R-3 Multi-Family Residential District	Accessory structures must be located more than five feet from any property line, and may not be located within a required front yard. Detached accessory structures may not occupy more than five percent of the lot.
O-1 Office-Institutional District	
B-1 Local Business District	
B-2 Central Business District	
B-3 Highway Business District	
I-1 General Industrial District	

400.13 Development Standards – Minimum Floor Area For Dwellings

All accessory buildings shall meet the following development standards

Zoning District	Development Standards
S-1 Open Space & Conservation	NA
R-1 Suburban Single Family Residential District	Dwellings shall have a minimum gross floor area of 1,500 square feet.
R-2 Medium Density Residential District	Dwellings shall have a minimum gross floor area of 1,000 square feet.
R-3 Multi-Family Residential District	Dwellings shall have a minimum gross floor area of 750 square feet
O-1 Office-Institutional District	NA
B-1 Local Business District	NA
B-2 Central Business District	Dwellings shall have a minimum gross floor area of 750 square feet
B-3 Highway Business District	NA
I-1 General Industrial District	NA

400.14 Planned Unit Development (PUD) District.

The purpose of the Planned Unit Development District (PUD) is to achieve, to the greatest possible degree, land development that is responsive to the natural and environmental assets and liabilities of a given site. The PUD should be a well-integrated development in terms of major design elements such as roads, drainage systems, utilities, and open space. The PUD also allows greater design flexibility so that natural features may be protected and development concentrated in an innovative and efficient manner.

General Requirements

A PUD may be located in any area of the Village of New Concord where the applicant can prove that a proposed development would meet the purpose of this Section. The tract of land proposed to be developed as a PUD must be owned, leased, or controlled by one person or single entity, and must be at least 5 contiguous acres in size.

Permitted and Conditional Uses

An applicant may propose to include any mixture of land uses which are listed as permitted or conditionally permitted in any zoning district, except industrial, with the following limitations: The proposed location of commercial uses shall not have an adverse impact upon adjacent property or the public health, safety, and morals. Not more than 35 percent of the gross acres in a proposed development may be devoted to commercial uses. Further, not more than 25 percent of the gross acres in a proposed development may be devoted to dwellings that are not detached single-family dwellings.

Development Standards

The following standards represent broad parameters under which all PUD developments must be designed:

Central Water & Sewer Facilities: All structures in developments approved as a PUD must be served by central water & sewer facilities.

Clustering Residential Development & Density: Clustering residential density is permitted and encouraged to provide required common open space. Overall, the area devoted to residential land uses shall have a maximum total density of four dwelling units per acre of land (net acres, excluding roads). This total density may, however, be clustered in particular areas of the development to a level of up to 10 dwelling units per net acre in any given area, provided, however, that no less than forty (40) percent of the site is devoted to useful and desirable common open space established to provide recreational opportunities and to preserve unique environmental features on the site.

Maximum Impervious Surface: For all areas proposed for residential uses in the development the amount of impervious surface proposed must not exceed 50 percent of the total developed residential area. For all areas proposed for commercial uses in the development, the amount of impervious surface proposed must not exceed 75 percent of the total commercial area.

Development Layout and Design: Specific residential density, as well as, the development intensity of non-residential uses and the development design and layout shall be based on the applicant's ability to provide sufficient evidence to the Planning Commission and the Village Council that the overall development displays excellence in design by properly considering: significant natural and historic features, topography, natural drainage patterns, roadway access and circulation, surrounding land uses, the enhancement of the general welfare of the public, and aesthetically desirable land development. Attractive landscaped buffers shall be provided between incompatible land use and activities.

Front, Side & Rear Setback Standards for Perimeter Lots: All lots that are located along the perimeter of the PUD shall have minimum front, side and rear setbacks equal to those that would normally be specified in the applicable conventional zoning district for the particular land use.

Common Space: A minimum of forty (40) percent of the gross acres developed in the PUD shall be reserved for common open space for the residents of the area. This required amount of common space shall be established as open space forever and provisions shall be established for maintenance and care. The legal articles relating to any organization of property owners in the development charged with such open space maintenance is subject to review and approval by the Village of New Concord. The Village Planning Commission and/or Village Council may require as a condition of final approval, any evidence deemed necessary to document that the required common space will remain in its stated condition forever (including such as legal documents as deed restrictions, conservation easements, etc.).

Front, Side, and Rear Setback Standards for Interior Lots: Within the PUD, the standards for setbacks shall be fully described in the proposed preliminary and final development plan submitted according to the requirements of this Section.

Off-Street Parking and Loading Facilities: For all land uses located within the PUD, the Parking and Loading standards contained in Article VI shall be applied.

General PUD Approval Procedure

The applicant for a PUD must submit both a preliminary plan and a final development plan. Property must also be rezoned to PUD and the decision to approve a final development plan and to rezone a property PUD are done concurrently. The final development plan, with all conditions, stipulations, requirements become the zoning requirements for that particular property. All development restrictions described in the final development plan and supporting documents become the official zoning requirements of the subject property.

Preliminary Development Plan Submission

The applicant shall submit 10 copies of a proposed preliminary plan to the Zoning Inspector along with the required application fee. The proposed preliminary development plan shall include the following:

Background Information

- Name, address and phone of the applicant
- Name and address of the registered surveyor, engineer and/or landscape architect who prepared the plan
- Legal description of the property
- Description of the present use of the property

- A statement of the conceptual overview of the development
- A description of the proposed provision of utilities
- A description of proposed ownership and maintenance of open spaces
- A description of the expected timing of the development
- A list of property owners within 500 feet of the proposed development

Plan Drawing

- A vicinity map
- A table showing the gross acreage devoted to various uses
- Location, type and density of development types
- Conceptual drainage plan
- Location of open spaces
- Buffers between incompatible land uses
- Proposed street layout
- Existing buildings, and any existing potential underground storage tanks
- Overlay maps showing topography in 2 foot increments (derived from field survey or aerial photography), and soil types.

Additional Information and Fees

The Village Planning Commission may at its sole discretion, require additional information such as maps, data, or reports including environmental impact studies and an archaeological survey of the property prepared by an appropriate professional. The applicant shall be responsible for all reasonable expenses incurred by the Village in reviewing the preliminary and final development plans or any modifications thereof. Such expenses are beyond the application fees established by Village Council and may include professional service fees such as legal fees and the fees for the services of other professionals such as geologists, landscape architects, planners, engineers, environmental scientists, or architects, incurred in connection with reviewing the plans and prepared reports.

Preliminary Plan Review

Within 30 days following the submission of the required information, a public hearing shall be scheduled on the proposed plan. Notice of this hearing shall be published in a newspaper of general circulation at least 15 days before such hearing. Notice of this hearing shall also be sent to all property owners within 500 feet of the proposed development.

Preliminary Development Plan Review as a Subdivision

Concurrently, with the PUD review procedure described herein, all PUD developments must also be reviewed as a subdivision pursuant to the Village Subdivision Regulations. Where possible, reviews and hearings will be held concurrently to facilitate timely action on proposed developments. Whenever the requirements of this Article conflict with requirements contained in the subdivision regulations, the provisions herein shall apply. Criteria for Approval of A Preliminary Development Plan.

Within twenty (20) days following the public hearing referenced in Section 406.7 above, the Village Planning Commission shall act to approve, disapprove or conditionally approve the preliminary plan according to the following criteria:

- That the proposed development is in conformity with the goals and objectives of the comprehensive plan.
- That the benefits, improved arrangement, and the design of the proposed development justify the deviation from standard development requirements included in the New Concord Zoning Ordinance.
- That the uses requested in the proposal are compatible with surrounding land uses.
- That there are adequate public services (e.g., utilities, fire protection, emergency service, etc.)

available to serve the proposed development.

- That the proposed development will not create overcrowding and/or traffic hazards on existing roads and/or intersections.
- That the arrangement of land uses on the site properly consider topography, significant natural features, natural drainage patterns, views, and roadway access.
- That the clustering of development sites are shown to preserve any natural or historic features and provide usable common open space.
- That the proposed road circulation system is integrated and coordinated to include a hierarchical interconnection of interior roads as well as adequate outer-connection of interior collector streets with off-site road systems.
- That there are adequate buffers between incompatible land uses.
- That the Village Planning Commission is satisfied that the developer possesses the requisite financial resources to begin the project within the required one year and complete the project within three years or within the phasing schedule.

Effect of Approval of the Preliminary Development Plan

The Planning Commission approval of a preliminary plan will be considered an approval of the preliminary development plan in principle only. Approval of the preliminary plan does, therefore, not approve any development on the site nor shall it be construed to absolutely endorse a precise location of uses, shape of parcels, or engineering feasibility. Approval of the Preliminary Development Plan is necessary, however, before the applicant may submit a Final Development Plan to the Planning Commission and Village Council for approval and rezoning to PUD.

Final Plan

The applicant shall submit ten (10) copies of the proposed Final Plan to the Village Zoning Inspector along with the required application fee. The final plan shall include all of the written information required for the preliminary plan application (See Section 406.6) revised as necessary and:

- The specific description of permitted, conditionally permitted and accessory uses to be allowed in each area of the development.
- A copy of proposed deed restrictions.
- Besides the information provided on the preliminary plan, the final plan shall be drawn to a maximum scale of (1" to 100') and include:
- A survey of the proposed development site, showing dimensions and bearings of the property lines; area in acres; topography; and existing features of the development site, including major wooded areas, streets, easements, utility lines, and land uses;
- The location and dimensions of all lots, setbacks, and building envelopes.
- Engineering drawings and plans of sewer and water facilities as well as, street and drainage systems.
- Landscaping plan for all buffers and other common areas.
- Architectural guidelines to apply throughout the development.
- The proposed names of all interior streets proposed for the development.
- Layout and dimensions of all parking and loading areas along with an indication of what they are to be built to serve.

Final plan and Rezoning Approval Procedure Process

The decision to rezone land to PUD and to approve the Final Plan are technically separate decisions. However, to provide for the efficient and timely processing of both the rezoning request and the request for final plan approval, all PUD final plan submissions are deemed to be an application for amendment to the Zoning Code according to Article XI. All procedures (Planning Commission review, public hearing, and final action by Council), therein shall be followed in considering an application for a rezoning of the land in question to PUD. Upon approval of such application to rezone the property in question to PUD, the Zoning District Map

of the Village of New Concord shall be amended to designate the project area as "PUD." Thereafter, with the concurrent approval of the rezoning and final plan pursuant to the criteria stated in Section 406.13, all development restrictions and conditions described in the Final Plan shall become official requirements of the PUD.

Criteria of Approval - Final Plan

The New Concord Planning Commission and the Village Council of New Concord shall review the proposed Final Plan according to the following criteria:

- That the proposed development is in conformity with the Goals and Objectives of the comprehensive plan.
- That the proposed development advances the general health, safety and morals of New Concord.
- That the New Concord Planning Commission and Village Council are satisfied that the developer possesses the requisite financial resources to begin the project within the required one year and complete the project within three years or within the phasing schedule.
- That the interior road system, proposed parking, and any off-site improvements are suitable and adequate to carry anticipated traffic generated by and within the proposed development.
- That any exception from standard district requirements can be warranted by design and other amenities incorporated in the final development plan, according to these PUD requirements.
- That the area surrounding said development can be planned and zoned in coordination and substantial compatibility with the proposed development.
- That the existing and proposed utilities, including water and sewer service, and drainage plan will be adequate for the population densities and non-residential uses proposed in the PUD.

Article V OVERLAY DISTRICTS

500.01 Overlay Districts

Along with the standard zoning districts established in Article IV, two additional overlay zoning districts are established which supplement underlying zoning requirements.

500.02 ARD Architectural Review District Overlay

The purpose of the Architectural Review District is to recognize, preserve, and enhance the historic character of the downtown area of New Concord, by safeguarding the architectural integrity of historic structures. This district is also established to discourage new construction or alternations of existing buildings that are determined to be detrimental to, and incompatible with, the existing architecture, physical form and historic atmosphere of the downtown area of New Concord. It is also recognized that beyond cultural benefits, the protection of historical resources in the Village will further the economic development of the area and will help maintain and improve area property values. The ARD District is an overlay zoning district that imposes development standards in addition to the standards contained in the underlying district.

500.03 Certificate of Appropriateness Required

A certificate of appropriateness is required prior to:

- Any new construction of a structure
- Any remodeling which involves the alteration of a foundation, alteration of a roof line, the enclosure of any porch, deck or breezeway, or the replacement of windows, or siding.
- The placement, replacement, or re-construction of any sign
- The demolition of any structure, except when a structure is declared unsafe and is an imminent peril.
- Exterior painting when colors are changed.

Nothing in this chapter shall be construed to prevent the ordinary maintenance or repair of any property

500.04 Establishment of a Design Review Board

There is hereby established a Design Review Board that shall have the authority to issue a Certificate of Appropriateness to those persons who, upon proper application, desire to make any changes other than ordinary maintenance to any structure, objects or property, real or otherwise, within the Architectural Review District. The issuance of a Certificate of Appropriateness within the Historic District Overlay Zone is required before issuance of a zoning permit issued by the Zoning Inspector.

500.05 Composition and Organization of the Design Review Board

The Design Review Board shall be composed of five (5) members, all citizens of the Village, appointed by the Mayor. Three (3) members shall constitute a quorum, and a majority vote of the board (3) shall be necessary to pass any motion. The Board shall meet as needed. In case of tie vote, the Village Zoning Inspector shall be called upon to cast a deciding vote. Member's terms shall be for five (5) years with each term staggered. The chairman shall be appointed by the Mayor.

500.06 Duties of the Design Review Board

The Design Review Board shall have the following duties:

- The Board may conduct surveys or otherwise assemble information related to all areas, places, buildings, structures, homes, works of art or other objects of environmental, architectural and aesthetic interest in the Village.
- The Board shall work for the continuing education of the residents of the Village with respect to the architectural and historic heritage of Village.
- The Board is hereby authorized to issue a certificate of appropriateness upon application. When a certificate of appropriateness is granted, it shall be directed to the Zoning Inspector who may issue a zoning permit provided all other sections of this code are complied with and shall precede the issuance of a permit.

500.07 Design Requirements & Review Criteria

In the review of applications for a certificate of appropriateness and other matters, the Board shall be guided by the following requirements and criteria:

- The distinguishing original qualities or character of a period building, structure or site and their environment shall not be destroyed. The removal or alteration of any historic material or distinctive architectural features should be avoided when feasible.
- All buildings, structures and sites shall be recognized as products of their own time. Alterations that have no historical basis and which seek to create an earlier appearance inconsistent or inappropriate to the original integrity of the building shall be discouraged.
- If changes to a building that have taken place in the course of the time are evidence of the history and development of a building, structure or site and its environment, and these changes are deemed to have acquired significance, then this significance (if any) shall be recognized and respected.
- Distinctive stylistic features or examples of skilled craftsmanship that characterize a building, structure or site shall be treated with sensitivity.
- Significant architectural features that have deteriorated shall be repaired rather than replaced, wherever possible. In the event replacement is necessary, the new material should match the material being replaced in design, color, texture and other visual qualities. Repair or replacement of architectural features should be based on accurate duplications of features, and if possible, substantiated by historic, physical or pictorial evidence rather than on conjectural designs or the availability of different architectural elements from other buildings or structures.
- The surface cleaning of structures shall be undertaken with methods designed to minimize damage to historic building materials. Sandblasting and other cleaning methods that will damage the historic building materials should be avoided.
- Every reasonable effort shall be made to protect and preserve archeological resources affected by, or next to any project.
- Contemporary design for alterations and additions to existing properties shall not be discouraged when such alterations and additions do not destroy significant historical, architectural or cultural material, and such design- is compatible with the size, scale, color, material and - character of the property, neighborhood or environment.
- Wherever possible, new additions or alterations to structures shall be done in such a manner that if such additions or alterations were to be removed in the future, the essential form and integrity of the original structure would be unimpaired.
- The Design Review Board may require applicants to explore alternatives to the demolition.
- The design of new structures and of additions to existing structures, including new site improvements, shall take into account the architectural style, general design, arrangement, texture, material and color of other structures and premises within the Architectural Review District.
- All new structures and all reconstruction or remodeling of existing structures shall use natural traditional exterior materials such as brick, stone, masonry and wood, where possible.

- Traditional colors and combinations of those colors that are both identified with the origin or the era in which the area was originally built, should be used for building exteriors for all new construction.
- All signs shall be of such a style or design that is reflected in the district, and shall conform to the requirements of Article VII. Sign size and shape shall also respond to the existing proportions of period structures, and signs shall not be permitted to cover or otherwise hide important architectural features.

500.08 Procedures

Applications for a certificate of appropriateness shall be filed with the zoning inspector, and the Design Review Board shall meet within 10 business days following the submission of a complete application. In addition to an application form, the Design Review Board shall specify the type of drawings, materials; sketches and material samples required which must accompany an application form.

The Design Review Board shall review, and approve, disapprove, or modify applications, and upon such approval, or approval with modifications shall issue a certificate of appropriateness. Such a decision must be made within seven (7) calendar days following the meeting, unless an extension is agreed to by the applicant.

500.09 Appeals

An applicant who has been denied a certificate of appropriateness by the Design Review Board may appeal the decision to the Board of Zoning Appeals. Any such appeal shall be made within ten (10) days after the complaint of action or inaction of the Board. Upon hearing such an appeal, the Board of Zoning Appeals, may reverse, affirm or modify the order or determination, and issue a certificate of appropriateness. The Board of Zoning Appeals shall base their decisions on the appeal criteria listed in Section 407.6 of this code.

500.10 State Route 83 Corridor Overlay District

The purpose of the SR 83 Corridor District Overlay is to help ensure that development and redevelopment of this corridor takes place in a manner that results in an efficient, safe, and attractive environment. The SR 83 Corridor is the primary gateway to New Concord, and its character, quality, appearance and urban design is highly significant. This area introduces visitors to the community and creates first impressions of civic desirability and quality. It is also very important that this corridor develop and redevelop with a high level of transportation functionality to help prevent accidents and congestion as vehicular movement increases.

The importance of the SR 83 Corridor justifies additional architectural requirements and development standards contained in this Overlay Zoning District. These standards are articulated in a separate document titled "State Route 83 South Friendship Drive, Design Framework Manual." This document is dated February 9, 2015 and has been adopted by both the New Concord Planning Commission and the New Concord Village Council. It provides, specific design principles to be followed.

500.11 Requirements:

All proposed development activity within the State Route 83 Corridor Overlay District is subject to Site Plan Review Procedures described in Article 7. This includes the construction of principal and accessory buildings, freestanding signs, parking lot construction/expansion and creation of outdoor use areas such as patios and recreation space.

ARTICLE VI SUPPLEMENTAL CONDITIONS

600.01 Buffering Requirements

To secure a desirable transition between residential and commercial and/or office/institutional land uses, additional requirements shall apply to side and/or rear yards beyond those requirements specified in the zoning districts. For parcels of land which are zoned O-1, B-1, B-2, B-3, I-1 and which abut an R-1, R-2, or R-3 zoning district, the minimum side and/or rear yards abutting such residentially zoned land shall be twice the dimension requirement normally required. These additional side and/or rear yards shall not contain any signs or parking areas of any kind, and shall have plantings of trees and/or shrubs that will have a minimum height of 4 ½ feet and will provide an opacity of 100 percent in the summer and 50 percent in the winter within 3 years. Existing vegetation shall be used to fulfill this requirement where feasible and all plant material shall be maintained in an attractive condition.

600.02 Adjustments to Side Yard Requirements For Corner Lots

Regardless of side setback line requirements and minimum side yard requirements set forth in other parts of this code, when a lot is located on a corner of intersecting streets, all yards abutting a public street shall be considered to be a front yard, and shall be required to have front yard setbacks and front yard requirements for all such yards abutting a public street.

600.03 Visibility at Intersections

In any district on any corner lot, no fence, structure or planting shall be erected or maintained within thirty (30) feet of the "corner" at a height between two and one-half (2-½) and ten (10) feet above curb or street grade, or so as to interfere with traffic visibility across the corner. The "corner" shall be the point of intersection of the two right-of-way lines.

600.04 Architectural Projections

Open structures such as porches, balconies, platforms, carports and covered patios, and similar architectural projections shall be considered a part of the building to which attached and shall not project into the required minimum front, side or rear yard. Ordinary projections of sills, belt courses, roof eaves, cornices and similar structural and ornamental features may extend to a distance not to exceed eighteen (18) inches into a required yard.

600.05 Double Frontage Lots

Lots having frontage on more than one street shall provide the required front yard along both streets.

600.06 Accessory Buildings

Accessory structures (when not attached to a principal structure) may be located within 5 feet of any property line; provided however, that an unattached accessory structure may not be located in an area that would place it closer to the street than the principal structure. Accessory buildings can only be placed on a lot with a principal structure.

600.07 Fences, Walls and Hedges

Fences, plant material and similar screening devices up to three (3) feet in height are permitted in yards fronting on the public street. Fences, walls and hedges up to six (6) feet in height are permitted in the remaining yards. The finished side of all fences shall be facing out

600.08 Swimming Pools

A private swimming pool but not farm ponds shall be any pool, lake or open tank not located within a completely enclosed building and containing or normally capable of containing water to a depth at any point greater than one and one-half (1-1/2) feet. No such swimming pool, exclusive of portable swimming pools with a diameter less than twelve (12) feet or with an area of less than one hundred (100) square feet, shall be allowed in any District except as an accessory use and unless it complies with the following conditions and requirements:

- A. The pool may not be located, including any walks or paved areas or accessory structure adjacent thereto, closer than ten (10) feet to any property line or In the front yard closer than the setback required in the district.
- B. The pool, or the entire property on which it is located, shall be so walled or fenced to prevent uncontrolled access from the street or from adjacent properties. Said fence or wall to be not less than five (5) feet in height and maintained In good condition with a gate and lock.

600.09 Club Swimming Pools:

A club swimming pool shall be any pool constructed by an association of property owners or by a private club for use by members and guests of the association or club. Community and club swimming pools are permitted in all districts, but shall comply with the following conditions and requirements:

- A. The pool and accessory structures thereto, including the areas used by the bathers, shall not be closer than one hundred (100) feet to any property line.
- B. The swimming pool and all of the area used by the bathers shall be so walled or fenced as to prevent uncontrolled access from the street or adjacent properties. The said fence or wall shall not be less than six (6) feet In height and maintained in good condition.

600.10 Outdoor Lighting

Outdoor lighting, when used for security, landscaping, or signage shall be so designed and directed so as not to adversely impact adjacent property.

600.11 Bed & Breakfast Establishments

Where allowed as a permitted or conditional use, bed and breakfast establishments must meet the following requirements:

- A. No more than 2 people are employed in the bed and breakfast who are not residents of the home.
- B. Bed and Breakfast establishments may have accommodations for no more than four guest rooms
- C. There shall be no external evidence of the bed and breakfast except for a single non-illuminated sign, made of materials other than plastic, affixed to the residence which has no more than 10 square feet of total sign area.

600.12 Parking or Storage of Trailers, Recreation Vehicles and Boats

Parking a trailer, recreation vehicle, or boat in any residential district on the street or in the front yard of any lot for more than seventy-two (72) hours shall be prohibited.

600.13 Height Regulations for Structures

The height regulations prescribed herein shall not apply to television and radio towers, church spires, belfries, monuments, tanks, water and fire towers, stage towers or scenery lofts, cooling towers, ornamental towers and spires, chimneys, silos and similar structures, elevator bulkheads, smokestacks, conveyors and flagpoles.

600.14 Requirement for Sexually-Oriented Businesses

Based on secondary effects studies conducted in other communities it is recognized that there are some uses which, because of their very nature, have serious secondary impacts upon adjacent residential and commercial use areas, and certain specific land uses such as schools, parks, child care facilities, public building and churches. Therefore, the Village recognizes that regulation of adult entertainment businesses is necessary to insure that adverse secondary impacts will not contribute to the blight and reduced property values. The Village of New Concord has reviewed available literature on the subject of the secondary effects of sexually-oriented businesses and determined that a sexually-oriented business shall be separated from other sensitive land uses and shall comply with the following requirements. All measurements shall be made using applicable lot lines and shall utilize a straight line representing the shortest distance between two points.

Sensitive land uses listed below include those existing outside of the corporate limits.

- A. Sexually-oriented businesses shall comply with the district regulations applicable to all properties in any district in which they are located.
- B. No sexually-oriented business shall be permitted in a location which is within 1,500 feet of another sexually-oriented business.
- C. No sexually-oriented business shall be permitted in a location which is within 1,000 feet of any school, park, child care facility, public building, place or religious worship, private school, park or playground, or any social services facility or neighborhood center.
- D. No sexually-oriented business shall be permitted in a location which is within 500 feet of any residence (inside or outside of the Village) or boundary of any residential district.

600.15 Minimum Standards for Single Family Dwellings

All single family dwelling units including industrialized units shall have, a complete foundation under all exterior walls, a pitched roof with a minimum 1 to 4 ratio between vertical rise and horizontal run and the minimum width of the narrowest portion of the main part of the house shall be 20 feet.

600.16 Outdoor Storage Restrictions

Where permitted and conditionally approved, any outdoor storage shall be in side or rear yards only, shall be totally screened from any street abutting the property and any residential property or district abutting the property, shall be a maximum of 6 feet in height, shall be set back a minimum of 10 feet from all property lines and shall occupy a maximum 20% of the area of the property which they are located.

600.17 Temporary Buildings

Temporary buildings may be permitted in any district under the following conditions one time per calendar year:

- A. The activity or purpose for the building is a permitted use within the district except when used for a community or charitable event one time per calendar year.
- B. The entire structure is removed from the premises within thirty (30) days of being placed or erected on any property or for any business or owners except that bonafide non-profit or community organizations may exceed thirty (30) days.
- C. All structures shall comply with applicable building codes and shall comply with all set-back

requirements.

600.18 Satellite Dish Receivers

Satellite dish type receivers shall be permitted in any district under the following conditions:

- A. A satellite dish may be located in the rear yard as defined herein, if it is less than six(6) feet in diameter, is a minimum of five (5) feet from any property line and is less than fifteen (15) feet high from ground level.
- B. A satellite dish may be located in a side yard if it is less than three (3) feet in diameter, less than four (4) feet in height from the ground level, a minimum of five (5) feet from any property line and cannot be viewed from any abutting street because of landscape screening.
- C. A satellite dish may be located on a rear roof of a structure if the dish is less than three (3) feet in diameter and cannot be viewed from any abutting street.
- D. A satellite dish may be located in a front yard if it is less than eighteen (18) inches in diameter, is five (5) feet from any property line, set back a minimum of twenty-five (25) feet from the street and cannot be viewed from any abutting street because of landscape screening.
- E. A satellite dish may be located on any structure if it is less than eighteen (18) inches in diameter, does not extend more than three (3) feet above the roof and will not property operate if located on a rear roof.

Any exception to the above requirements shall require a variance as defined herein. Any landscape screening requirement shall be maintained year round.

600.19 Conversion of Dwellings

The conversion of any building into a dwelling or the conversion of any dwelling so as to accommodate an increased number of dwelling units or families, shall be permitted only within a district in which a new building for similar occupancy would be permitted under this Zoning Ordinance, and only when the resulting occupancy will comply with the requirements governing new construction in such district, with respect to minimum lot size, lot area per dwelling unit, dimensions of yard and other open spaces, percentage of lot coverage, building height, and off-street parking. When an existing single-family dwelling is converted contain more than one dwelling unit, the converted dwelling shall retain the appearance of a single-family dwelling with no significant or noticeable change and shall have no major structural alterations to the exterior of the building, other than to provide required means of ingress and egress from dwelling units. All fire escapes or stairways leading to a second floor must be completely enclosed within the converted building. Each conversion shall be subject also to such further requirements that apply to such district or use.

600.20 Street Access-Curb Cuts-Driveways

No person shall construct or alter any type of private access for vehicular or other traffic to a public street or alley including driveways, sidewalks, private streets, roads or paths without first obtaining a permit. No permit shall be issued if the access way creates a safety hazard or will impede public services.

600.21 Out-Door Furnaces

Outdoor furnaces and heating devises shall be prohibited in all distracts within the Village.

600.22 Parking Area Maintenance.

All parking areas required herein to be paved with asphalt, concrete, or brick pavers shall be maintained in a good workman like condition with the same material. Any change in the surface shall be to another hard

surface pavement approved by the Zoning Inspector or shall require a zoning variance as required herein.

600.23 Generators and Turbines

No electrical generating device for use other than during emergencies, construction or power outages shall be installed without first obtaining conditional use approval from the Planning Commission in accordance with criteria listed in section 1000.3.

600.24 Roof Mounted Solar Collection Systems and Free Standing Solar Collection Systems

Roof Mounted and/or Free Standing Solar Collection System shall not be permitted until a Zoning Permit has been obtained from the Village of New Concord. The fee for permits shall be the same amount as Commercial or Residential Accessory Structure permits for the use. No permit shall be issued or approved by the Village and construction shall not commence for any Solar Collection Systems until plans showing satisfactory evidence that all requirements of this ordinance have been complied with and that storm water runoff control complies with other applicable ordinances. Site Plan approval by the Planning Commission shall not be required for Solar Collection Systems. The provisions of this ordinance shall in no way limit the use of any property by limiting tree planting or construction of any structure permitted by law.

600.25 Roof Mounted Solar Collection Systems

Roof Mounted Solar Collection systems shall be considered an accessory use in all zoning districts if constructed and maintained in accordance with the following requirements:

- A. All structures used for the placement of Roof Mounted Solar Collection Systems shall have a minimum height of eight feet from ground level to any Solar Collection Systems.
- B. Roof Mounted Solar Collection Systems installed on buildings shall not project horizontally beyond the roof of any building.
- C. All recommended manufacturers' or installers' identification and appropriate warning signage shall be posted on or near the panels in a clearly visible manner.
- D. No solar energy system shall be installed until evidence has been given to the Village of New Concord that the system complies with the laws of the State of Ohio including; the Ohio Building Code, National Electric Code and all manufacturer's specifications.

600.26 Roof Mounted Solar Collection Systems in Architectural Review Overlay District

No Roof Mounted Solar Collection Systems, panels, equipment or devise shall be installed in the Architectural Review Overlay District whatsoever without first receiving approval of the Design Review Board as required by this Zoning Code. Any Roof Mounted Solar Collection Systems, panels, equipment or devise installed on the front side of pitched roofs facing the street or on flat roofs in a manner so as to be visible from the street at ground level in the Architectural Review Overlay District shall be designed and installed in a manner to mimic the roof and shall be compatible with the buildings architecture and the historic nature of the district. Panels that project more than twelve inches above the roof or are constructed at an angle different from a pitched roof shall not be permitted.

600.27 Free Standing Solar Collection Systems – under 25,000 Sq. Ft. in total area.

Free Standing Solar Collection Systems that are less than 25,000 square feet are listed as a permitted use in certain districts if constructed and maintained in accordance with the following requirements:

- A. Free Standing Solar Collection Systems shall be a minimum of 300 feet from any other Free Standing Solar Collection Systems regardless of property ownership.

- B. Free standing solar panels located on the ground or attached to a framework located on the ground shall not exceed twenty (20) feet in height above the ground.
- C. All recommended manufacturers' or installers' identification and appropriate warning signage shall be posted on or near the panels in a clearly visible manner.
- D. No solar energy system shall be installed until evidence has been provided to the Village of New Concord that the system complies with the laws of the State of Ohio including; the Ohio Building Code, National Electric Code and all manufacturer's specifications.
- E. Free Standing Solar Collection Systems shall be located a minimum of 200 lineal feet from the nearest residential district or public street
 - a. except that the minimum setback from the nearest residential district or public street for Free Standing Solar Collection Systems may be reduced to 100 lineal feet provided that it is effectively screened on each side that adjoins or faces any public street or residential zoning district by a fence or hedge not less than six (6) feet in height that shall be maintained in good condition.
 - b. The space between such wall or fence and the lot line of the adjoining Residential District or public street shall be landscaped with grass, hardy shrubs, or evergreen ground cover and maintained in good condition.
 - c. In lieu of such wall or fence, a strip of land not less than six (6) feet in width and planted and maintained with an evergreen hedge or dense planting of evergreen shrubs not less than six (6) feet in height may be substituted.

Maintenance

- A. All free standing solar collection systems shall be maintained in proper working order.
- B. Any physical modification to the free standing solar collection system that alters the mechanical load, mechanical load path, or major electrical components shall require re-application for conditional use under this section. Like-kind replacements shall not require re-application.
- C. All free standing solar collection system sites shall be maintained to the desired community standards including but not limited to the following:
 - a. Free of weeds and tall grass
 - b. Free of debris
 - c. Shall remain clean and free of peeling paint or unsightly damage
 - d. The above standards, along with all applicable requirements for screening, apply to any screening that may be installed around the free standing solar collection system.

Abandonment

- A. Any free standing solar collection system that is out-of-service for a continuous 12 month period will be deemed to have been abandoned. The Zoning Officer may issue a Notice of Abandonment to the owner of the free standing solar collection system that is deemed to have been abandoned. The owner shall have the right to respond to the Notice of Abandonment within 30 days from the Notice receipt date. The Zoning Officer shall withdraw the Notice of Abandonment and notify the owner that the Notice has been withdrawn if the owner provides information that demonstrates the free standing solar collection system had not been abandoned.
- B. If the free standing solar collection system is determined to be abandoned, the owner shall remove the system within 90 days of the Notice of Abandonment and the site must be reclaimed to a depth of two (2) feet, if necessary. If the owner fails to remove the free standing solar collection system and reclaim the site, the Village may remove or cause the removal of the system and the reclamation of the site. The cost of removal and reclamation will become a lien upon the property and may be collected in the same manner as property taxes.

600.28 Free Standing Solar Collection Systems—more than 25,000 Sq.Ft. & under 100,000 Sq.Ft.

Free Standing Solar Collection Systems that are more than 25,000 square feet in total area but less than 50,000 square feet in total area are conditional uses certain districts and Free Standing Solar Collection Systems that are 50,000 square feet in total area or more, but less than 100,000 square feet are also conditional uses in certain districts subject to the following requirements:

- A. Free Standing Solar Collection Systems shall be a minimum of 300 feet from any other Free Standing Solar Collection Systems regardless of property ownership.
- B. Free standing solar panels located on the ground or attached to a framework located on the ground shall not exceed twenty (20) feet in height above the ground.
- C. All recommended manufacturers' or installers' identification and appropriate warning signage shall be posted on or near the panels in a clearly visible manner.
- D. No solar energy system shall be installed until evidence has been provided to the Village of New Concord that the system complies with the laws of the State of Ohio including; the Ohio Building Code, National Electric Code and all manufacturer's specifications.
- E. Free Standing Solar Collection Systems shall be located a minimum of 200 lineal feet from the nearest residential district or public street
 - a. except that the minimum setback from the nearest residential district or public street for Free Standing Solar Collection Systems may be reduced to 100 lineal feet provided that it is effectively screened on each side that adjoins or faces any public street or residential zoning district by a fence or hedge not less than six (6) feet in height that shall be maintained in good condition.
 - b. The space between such wall or fence and the lot line of the adjoining Residential District or public street shall be landscaped with grass, hardy shrubs, or evergreen ground cover and maintained in good condition.
 - c. In lieu of such wall or fence, a strip of land not less than six (6) feet in width and planted and maintained with an evergreen hedge or dense planting of evergreen shrubs not less than six (6) feet in height may be substituted.

Maintenance

- A. All free standing solar collection systems shall be maintained in proper working order.
- B. Any physical modification to the free standing solar collection system that alters the mechanical load, mechanical load path, or major electrical components shall require re-application for conditional use under this section. Like-kind replacements shall not require re-application.
- C. All free standing solar collection system sites shall be maintained to the desired community standards including but not limited to the following:
 - a. Free of weeds and tall grass
 - b. Free of debris
 - c. Shall remain clean and free of peeling paint or unsightly damage
 - d. The above standards, along with all applicable requirements for screening, apply to any screening that may be installed around the free standing solar collection system.

Abandonment

- A. Any free standing solar collection system that is out-of-service for a continuous 12 month period will be deemed to have been abandoned. The Zoning Officer may issue a Notice of Abandonment to the owner of the free standing solar collection system that is deemed to have been abandoned. The owner shall have the right to respond to the Notice of Abandonment within 30 days from the Notice receipt date. The Zoning Officer shall withdraw the Notice of Abandonment and notify the owner that the Notice has been withdrawn if the owner provides information that demonstrates the free standing solar collection system had not been abandoned.
- B. If the free standing solar collection system is determined to be abandoned, the owner shall remove the system within 90 days of the Notice of Abandonment and the site must be reclaimed to a depth of two (2) feet, if necessary. If the owner fails to remove the free standing solar collection system and reclaim the site, the Village may remove or cause the removal of the system and the reclamation of the site. The cost of removal and reclamation will become a lien upon the property and may be collected in the same manner as property taxes.

600.29 Generators, Turbines and Wind Energy Conversion Systems

No electrical generating device for use other than during emergencies, construction or power outages (unless located in the B3 zoning district as specified below) shall be installed without first obtaining conditional use approval from the Planning Commission in accordance with criteria listed in section 1000.3.

Definitions

Fall Zone – The potential area on the ground within a prescribed radius from the base of a wind energy conversion system (WECS). The fall zone in the area within which there is a potential hazard from falling debris (such as ice) shall not be less than a radius equal in distance to the total height of the WECS.

Shadow Flicker – This is the on and off flickering effect of a shadow caused when the sun passes behind the rotor of a wind turbine.

Total Height – Total height is the vertical distance from the base of the tower to the tip of a wind generator blade when the tip is at its highest point.

Wind Energy Conversion System (WECS) – Equipment that converts and then stores or transfers energy from the wind into usable forms of energy and includes any base, blade, foundation, generator, nacelle, rotor, tower, transformer, turbine, vane, wire or other component used in the system.

Wind Energy Conversion System, Small – A wind energy system that has a total height of 75 feet or less, and is primarily used to generate energy for use by its owner, reduce the need to purchase utility power from the grid, and has the ability to sell power back to the grid.

Wind Energy Conversion System, Medium – A wind energy system that has a total height of 170 feet or less, and is primarily used to generate energy for use by its owner, reduce the need to purchase utility power from the grid, and has the ability to sell power back to the grid.

Power Grid – The transmission system created to balance the supply and demand of electricity consumers in Ohio.

Professional Engineer – A qualified individual who is licensed as a Professional Engineer in the State of Ohio.

Tower – The monopole or guyed monopole constructed to support a wind turbine or wind energy system.

Applicability

No wind turbine or wind energy conversion system (WECS) governed by this section shall be constructed, erected, installed or located within the Village limits until proper site approval has been obtained pursuant to the Zoning Code as follows:

- A. Wind turbine or WECS shall be conditionally permitted pursuant to section 1200.03 in the B3 zoning district.
- B. No wind turbine or WECS shall be erected, installed, located or modified, except as permitted in this section without first receiving a conditional use permit from the Village of New Concord.
- C. No wind turbine or WECS shall be erected, installed, located or modified, except as permitted in this section without first receiving zoning compliance pursuant to this section from the Village as well as receiving approval from other appropriate approving agencies, such as the Mid-East Ohio Building Department and/or the applicable electricity provider in the area.
- D. Only one wind turbine or WECS shall be permitted per parcel.

Design

Any wind turbine or WECS shall be designed as a monopole tower, Lattice towers are prohibited. All electrical wires associated with a WECS or wind turbine shall be located within the structure or tower and underground.

Blade Clearance

The vertical distance from the ground level to the tip of a wind energy generator blade when the blade is at its lowest point must be at least 40 feet. No blades may extend over parking areas, driveways or sidewalks.

Visual Impacts

- A. The exterior surface of any visible component of a WECS must be a non-reflective neutral color that blends with the surrounding environment.
- B. The wind turbine or WECS shall not be artificially lit unless such lighting is required by the Federal Aviation Administration (FAA). If lighting is required, the applicant shall provide a copy of the FAA determination to establish the required markings and/or lights for the wind turbine or WECS.
- C. The applicant shall demonstrate through project site planning and proposed mitigation that a wind turbine or WECS's visual impacts will be minimized for surrounding neighbors and the community. This may include, but not be limited to information regarding site selection, wind turbine or WECS design or appearance, buffering, and screening of ground mounted electrical and control equipment.

Utility Connection

Wind Turbine or WECS proposed to be connected to the local utility power grid through net metering shall adhere to Ohio Revised Code Section 4928.67 or any future corresponding statutory provision.

Access

- A. All ground mounted electrical and control equipment shall be labeled and secured to prevent

- unauthorized access.
- B. The tower shall not have a ladder or step bolts accessible to the public within 10 feet of the ground.

Clearing

Clearing of natural vegetation shall be limited to that which is necessary for the construction, operation and maintenance of the wind turbine or WECS and as otherwise prescribed by applicable laws, regulations and ordinances.

Setbacks

- A. The minimum setback distance for a small wind turbine or WECS, 75 feet total height, and all surrounding development area boundaries, overhead utility or transmission lines, and public rights of ways shall be equal to no less than 100 feet. Furthermore the fall zone for any wind turbine or WECS must be kept free of all occupied buildings during the operational life of the tower.
- B. The minimum setback distance for a medium wind turbine or WECS, 170 feet total height, and all surrounding development area boundaries, overhead utility or transmission lines, and public rights of ways shall be equal to no less than 205 feet. Furthermore the fall zone for any wind turbine or WECS must be kept free of all occupied buildings during the operational life of the tower.

Control and Brakes

All wind turbine and WECS shall be equipped with a redundant braking system which must include:

- A. Aerodynamic over-speed controls which include variable pitch , tip and other similar systems; and
- B. Mechanical brakes which must be operated in fail-safe mode.

Stall regulation shall not be considered a sufficient braking system from over-speed protection.

Sound Level

Operation of a wind turbine or WECS shall not exceed 50 decibels, except during short-term events such as severe wind storms and utility outages. This information shall be obtained from the manufacturer of the wind turbine or WECS, and all readings, if necessary, shall be taken from the nearest neighboring property line.

Signs

All signs, both temporary and permanent, are prohibited on wind turbine or WECS except as follows:

- A. Manufacturer's or installer's contact identification information on the wind turbine or WECS which shall be affixed to the base of the tower limited to two square feet in size.
- B. Appropriate warning signs and placards
- C. Advertising of any type shall not be permitted on the wind turbine or WECS unless the Planning Commission is willing to approve it as a conditional use per section 900.13, Expressway Signs, per the Village Zoning Code.

Maintenance

- D. All wind turbine or wind energy systems shall be maintained in proper working order.
- E. Any physical modification to the WECS that alters the mechanical load, mechanical load path, or major electrical components shall require re-application for conditional use under this section.

Like-kind replacements shall not require re-application.

- F. All WECS sites shall be maintained to the desired community standards including but not limited to the following:
 - a. Free of weeds and tall grass
 - b. Free of debris
 - c. Shall remain clean and free of peeling paint or unsightly damage
 - d. The above standards, along with any applicable requirements for screening, apply to any screening that may be installed around the WECS.

Abandonment

- C. Any WECS that is out-of-service for a continuous 12 month period will be deemed to have been abandoned. The Zoning Officer may issue a Notice of Abandonment to the owner of the WECS that is deemed to have been abandoned. The owner shall have the right to respond to the Notice of Abandonment within 30 days from the Notice receipt date. The Zoning Officer shall withdraw the Notice of Abandonment and notify the owner that the Notice has been withdrawn if the owner provides information that demonstrates the WECS had not been abandoned.
- D. If the WECS is determined to be abandoned, the owner shall remove the WECS within 90 days of the Notice of Abandonment and the site must be reclaimed to a depth of four (4) feet. If the owner fails to remove the WECS and reclaim the site, the Village may remove or cause the removal of the WECS and the reclamation of the site. The cost of removal and reclamation will become a lien upon the property and may be collected in the same manner as property taxes.

600.29 Mobile Retail Food Establishments

Mobile retail food establishment courts are designated as a conditional use within the B2 Zoning District. This district is covered by the Design Review Board overlay district which strives to preserve the historic nature of downtown New Concord. All pertinent guidelines for this district, as well as the B2 zoning district, apply. All potential mobile retail food establishment courts must be contained on an off-street lot and must abide by the following guidelines. No food trucks and/or trailers may be located on a public street.

- A. Duration: Food trucks and/or trailers are semi-permanent and must move at least once within a prescribed number of days per Muskingum County Health Department regulations
- B. Number/density of food trucks and/or trailers allowed per lot: 1 unit for every 4,000 square feet within the lot.
- C. Parking and Surfacing: Refer to Article VII – Off Street Parking and Loading Requirements for Restaurants, Nightclubs, Cafes or Similar Establishments.
- D. Site Amenities:
 - a. permanent restroom facilities
 - b. designated eating areas
 - c. landscaping throughout lot and screening at perimeter of lot on all sides
- E. Trash: A dumpster must be provided on-site as well as trash receptacles for designated eating areas. Each required dumpster will be screening from view. Refer to Article VII, Section 700.07 for additional information regarding dumpster and waste receptacle screening.
- F. Lighting: Appropriate lighting is required for Mobile Retail Food Establishment Courts during non-

daylight hours of operation. Refer to Article VII, Section 700.10 for additional information.

- G. Signage: Food Trucks and/or Trailers are used not only for food preparation, storage and sale but for advertisement as well. Where applicable the Design Review Board shall review and approve of signage/advertisement on any new food truck and/or trailer. A new food truck and/or trailer refers to a new design for the unit and/or a new food offering.

A mobile retail food establishment court may provide one (1) freestanding sign for the entire lot so as to guide potential customers to the court. For each food truck and/or trailer located within the mobile retail food establishment court the area of signage on the unit shall be as follows, or less:

- a. 30% of each “long” side of the unit may be covered in signage for the particular food offering of that unit.
- b. 15% of each “short” side of the unit may be covered in signage for the particular food offering of that unit.

Refer to Article IX – Signs and Outdoor Advertising Structures, Mobile Retail Food Establishment Court for additional details.

- H. Food Preparation: All food preparations and equipment used in food preparation must be approved by the Muskingum County Health Department before the Village of New Concord will allow the food truck and/or trailer to operate within the Village.

- I. Owner Responsibility in the event of a Cease of Operation

Should an owner of a Mobile Retail Food Establishment Court cease operations the owner is responsible for removing all trucks/trailers and freestanding signs from the lot. The lot shall be secured properly by the owner and the owner shall maintain the lot to the Village’s standards until ownership changes. Three months of consecutive non-operation constitutes a “cease of operation”.

- J. Planned/Necessary Interruptions in Operations

The owner of a Mobile Retail Food Establishment Court shall contact the Village Zoning Officer in the event of a planned or necessary interruption in operations. This interruption must be temporary in nature and the owner shall continue all lot maintenance as required per the Village’s standards. All utility hook up materials shall be properly secured and be aesthetically acceptable per the Zoning Officer’s inspection.

- K. Food Truck/Trailer Maintenance

Each unit, truck or trailer, shall be maintained to an acceptable aesthetic, cleanliness, and functionality level by the owner of a Mobile Retail Food Establishment Court. Units will be rust free, in good working order, have a clean appearance, and display Village approved & maintained signage/paint/graphics.

- L. Approval Process

Each potential mobile retail food establishment court must submit a site plan to the Zoning Officer for review. As this use requires conditional approval the Zoning Officer will forward the request to the Planning Commission for review.

If the mobile retail food establishment court is located within the Design Review Board overlay district the Zoning Officer will forward this information to the Design Review Board for review. Both the Planning Commission and the Design Review Board will work together to review any such site plan.

Once approved, the mobile retail food establishment court will submit plans/drawings for any freestanding sign or signage located on a new food truck and/or trailer to the Zoning Officer for approval.

ARTICLE VII OFF-STREET PARKING AND LOADING REQUIREMENTS

700.01 Off-street Parking - General Requirements

In all districts, In connection with every industrial, business, institutional, recreational, residential, or other use, there shall be provided, at any time any building or structure is erected or is enlarged or increased in capacity, off-street parking spaces for automobiles In accordance with the following requirements:

- A. Each off-street parking space shall have an area of not less than one hundred eighty (180) square feet exclusive of access drives or aisles, and shall be of usable shape and condition.
- B. There shall be adequate provision for ingress and egress to all parking spaces. Where a lot does abut on a public or private alley or easement of access, there shall be provided an access drive not less than eight (8) feet In width In the case of a dwelling, and not less than twenty (20) feet in width in all other cases, leading to the parking or storage or loading or unloading spaces required hereunder.

700.02 Number of Spaces Required

The number of off-street parking spaces to be provided shall not be less than the following:

Use	Parking Spaces Required
Dwellings, including 1, 2, and 3 families, multiple dwellings, summer cottages and mobile homes.	One (1) for each dwelling unit, if a single or two family dwelling, and one and one-half (1-1/2) spaces for each dwelling in multiple dwelling unit.
Rooming or boarding house, tourist home.	One (1) for each sleeping room or suite.
Hotel or motel.	Five (5) parking spaces plus one (1) parking space for each sleeping room or suite. These spaces shall be In addition to the parking spaces that shall be provided for any portion of the hotel that is used for office, business, or commercial purposes including the lobby, but not including corridors giving access to sleeping rooms.
Private club, golf club or lodge.	One (1) for each four (4) members.
Golf course.	Forty (40) for each nine (9) holes plus one (1) for each employee.
Church or temple.	One (1) for each five (5) seats In main auditorium.
School (except high school or college).	One (1) for each five (5) seats In auditorium or main assembly room, or two (2) for each classroom, whichever is greater.
College or high school.	One (1) for each six (6) seats in main auditorium or four (4) for each classroom, whichever is greater.
Community center, library, museum or art gallery.	Ten (10) plus one (1) additional for each three hundred (300) square feet of floor area in excess of

	two thousand (2,000) square feet.
Convenience store	One (1) space for each two hundred (200) square feet of gross floor area
Health care facility – medical offices	One (1) space per two hundred fifty 250 square feet of gross floor area – or two (2) spaces per each examination or treatment room, and one (1) space per each employees (whichever is greater)
Hospital.	One (1) for each bed.
Sanitarium, convalescent home, home for the aged or similar institution.	One (1) for each four (4) beds.
Offices and professional services.	One (1) for every one hundred (200) square feet of floor space
Retail business or business service establishment.	One (1) for each two hundred fifty (250) square feet of floor space and one for each two (2) employees on the maximum working shift.
Theater or auditorium (except school auditorium), sports arena, stadium or gymnasium.	One (1) for each five (5) seats or bench seating spaces.
Bowling alley.	Five (5) for each alley, plus one (1) additional space for each two hundred (200) square feet of area used for eating, drinking or other recreation.
Mortuary or funeral home.	One (1) for each fifty (50) square feet of floor space in slumber rooms, parlors, or individual funeral service rooms.
Restaurants, nightclubs, cafes or similar establishment.	One (1) space for each for (4) seats, or (1) space for each one hundred (100) square feet (including outside seating).
Furniture or appliance store, hardware store, wholesale establishment, machinery or equipment sales and services	Two plus one (1) additional space for each six hundred (600) square feet of floor area over one thousand (1,000) square feet.
Manufacturing, industrial or mining establishment, research or testing laboratory, creamery, bottling plant, or warehouse similar establishment.	One for each two (2) employees on the maximum working shift plus space to accommodate all trucks and other vehicles used in connection therewith.
Recreation or amusement establishments, dance halls, assembly or exhibition halls without fixed seats.	One (1) space for every five (5) persons of maximum occupancy capacity of building or assembly place.
Warehouse	One half (0.5) space per one thousand (1,000) square feet and one (1) space per two (2) employees

700.03 Interpretation:

The following rules shall govern the determination of spaces required:

- A. "Floor area" shall mean the gross floor area of the specified use.
- B. Fractional numbers shall be increased to the next whole number.
- C. The parking space requirement for a use not specifically mentioned herein shall be the same as required for a use of similar nature.
- D. Whenever a building or use constructed or established after the effective date of this ordinance is changed or enlarged in floor area, number of employees, number of dwelling units, seating capacity

or otherwise, to create a need for an increase of ten (10) percent or more in the number of existing parking spaces, such spaces shall be provided on the basis of the enlargement or change. Whenever a building or use existing prior to the effective date of this ordinance is enlarged to the extent of fifty (50) percent or more in floor area or in the area used, said building or use shall then and thereafter comply with the parking requirements set forth herein.

- E. Upon application, the Planning Commission may approve shared parking arrangements provided there is a written agreement binding involved property owners.

700.04 Special Parking Provisions

Every parcel of land hereafter used as a public, commercial or private parking lot shall be developed and maintained in accordance with the following requirements.

700.05 Screening

Off-street parking areas for more than five (5) vehicles shall be effectively screened on each side that adjoins or faces premises situated in any residential zoning district by a fence or hedge not less than four (4) feet or more than six (6) feet in height and shall be maintained in good condition without any advertising thereon. The space between such wall or fence and the lot line of the adjoining premises in any "R" District shall be landscaped with grass, hardy shrubs, or evergreen ground cover and maintained in good condition. In lieu of such wall or fence, a strip of land not less than six (6) feet in width and planted and maintained with an evergreen hedge or dense planting of evergreen shrubs not less than four (4) feet in height may be substituted.

700.06 Parking Lot Landscaping

Whenever an off-street parking lot includes twenty (20) or more parking spaces, at least one (1) deciduous tree of at least two and a half (2 1/2) inch caliper shall be provided for every ten (10) parking spaces (including the first 20). Such trees shall be located within parking islands or within five (5) feet of the edge of the parking lot. A minimum distance of three (3) feet shall be established between proposed tree or shrub plantings and the edge of curbing and pavement, or property line.

700.07 Dumpsters and Waste Receptacle Screening

Dumpsters, including waste receptacles and compactors, shall be designed, constructed and maintained according to the following.

- A. Dumpster location and details of construction shall be shown on site plans.
- B. Dumpsters shall be located in the rear yard or non-required side yard, unless otherwise approved by the Planning Commission and shall be no less than, twenty (20) feet from any adjacent residential district, or existing residence.
- C. Dumpsters shall be easily accessed by refuse vehicles without potential damage to automobiles parked in designated parking spaces.
- D. Dumpsters shall have an enclosing lid or cover.

700.08 Pedestrian Connections in Parking Lots from the Row to Entrances.

Parking lots shall provide and maintain specific defined spaces for pedestrian movement. All principal buildings featuring a customer or general public entrance, shall delineate areas for pedestrian movement between the public sidewalk the principal customer entrance in the parking lot. This pedestrian space shall be distinguished from driving surfaces with the use of durable, low-maintenance surface materials such as brick pavers, scored concrete, stamped concrete, pavement textures or painted surfaces to define places of pedestrian movement.

700.09 Surfacing

Any off-street parking area for more than five (5) vehicles shall be graded for proper drainage to an approved system and paved with brick, concrete or asphalt so as to provide a durable and dustless surface.

700.10 Lighting:

Any lighting used to illuminate any off-street parking area shall be so arranged as to reflect the light away from adjoining premises in any "R" District.

700.11 Off street Loading Requirements

In any district, in connection with every building or part thereof hereafter erected and having a gross floor area of ten thousand (10,000) square feet or more, which is to be occupied by manufacturing, storage, warehouse, retail store, wholesale store, market, hotel, hospital, mortuary, dry cleaning or other uses similarly requiring the receipt or distribution by vehicle of material or merchandise, there shall be provided and maintained on the same lot with such building at least one (1) off street loading space, plus one (1) additional such loading space for each additional twenty thousand (20,000) square feet or major fraction thereof of gross floor area when required because of the volume or receipt or distribution by vehicle of material or merchandise.

700.12 Location of Loading Spaces

No loading spaces shall be located closer than fifty (50) feet to any lot in a residential district, unless wholly within a completely enclosed building or unless enclosed on all sides facing lots in any residential district by a wall or fence not less than six (6) feet in height.

ARTICLE VIII SITE PLAN REVIEW PROCEDURES

800.01 Site Plan Review – Purpose

The purpose of site plan review procedures and requirements is to provide a means and process wherein proposed development of structures and establishment of land uses of a certain size and magnitude can be reviewed and considered in light of the need to:

- A. Balance a landowners right to use his/her land, with the corresponding rights of abutting and neighboring landowners to live without land use conflicts that might arise from “light spillover,” noise and visual impacts.
- B. Consider the convenience and safety of vehicular and pedestrian movement within the site, and in relation to adjacent areas or roads;
- C. Review how utility infrastructure will be addressed
- D. Address issues related to the protection of natural features on a site.
- E. Evaluate how proposed land development contributes to community aesthetics and creates a sense of place that is contextual with community character.

800.02 Projects Requiring Site Plan Review

Site Plans are required whenever any one of the following conditions exist:

- A. Proposed construction of any new principal use of property, except for new single or two family dwellings or any residential or non-residential accessory building.
- B. Any proposed construction, alteration, relocation or change in land use that results in the need for 5 or more off-street parking spaces pursuant to Article 6.
- C. Whenever specifically required by an Overlay Zoning District.

800.03 Site Plan Submissions

An applicant proposing a development subject to Site Plan Review under this section shall submit ten (10) copies each of the Site Plan and related documents, along with the required application fee. When other approvals are required, such as conditional uses or variances, any additional required information shall be submitted with the site plan, and related approval issues shall be addressed by the appropriate board subsequent to site plan review by the Planning Commission.

800.04 Site Plan Procedures

After determining that an application for site plan approval is complete, the Zoning Inspector shall transmit copies of the application to the Planning Commission and other municipal officials as necessary. If all information required is not provided, the Zoning Inspector shall promptly notify the applicant of the items needed. Following the determination that the application is complete, and after proper notifications are provided, the Planning Commission shall consider the proposed Site Plan and take action. Action on the site plan shall consist of either:

- A. Approval of the site plan based upon a determination that the proposed plan is in compliance with the standards set forth herein: or
- B. Approval of the site plan, subject to any conditions, modifications, and restrictions that will ensure that the project meets the standards set forth herein.

- C. The Planning Commission may table a Site Plan approval decision pending the provision of specific information, additional plan details, redesign of the all or part of the site layout or other information necessary to make an informed decision.

800.05 Submission Requirements

A site plan shall be prepared at a scale of 1 inch equal twenty feet (20 ft.). Developments greater than five acres may be drawn at a scale of 1 inch equal fifty feet (50 ft.) on standard 24" x 36" sheets. A site plan shall include all data, details, and supporting information as required to demonstrate compliance with code requirements. Review fees may be required to defray the expenses associated with the public review of the plans, including the need to retain a registered professional engineer, planner, landscape architect or other professional consultant to advise the Planning Commission on any or all aspects of the site plan.

800.06 Plan Review

After the Zoning Inspector has found the Site Plan to be complete with respect to the requirements herein, the Planning Commission shall consider such a plan at a public meeting, and act to approve the site plan as submitted, or approve the site plan with modifications. The Planning Commission must act to either approve the Site Plan as submitted, or it must approve it with specific modifications and changes. When modifications or changes are required as a condition of approval, a revised site plan with such modifications shall be submitted and filed. The Planning Commission and the applicant may mutually agree to table a Site Plan approval decision if there are outstanding issues and unresolved concerns.

In conducting its review, the Planning Commission shall consider the Standards for Review contained in this Article. The Planning Commission, may if circumstances warrant, limit the number of driveways into or out of a development to maintain better traffic flow on the public street, reposition driveways, require additional buffering, or yard requirements to maintain a better separation of pedestrian and traffic movement, and may require greater building setbacks to achieve more desirable and safer pedestrian and traffic movement. The Planning Commission may also consider other modifications to the submitted site plan that brings the proposed development into better alignment with the Site Plan Review Criterial and Standards (Section 700.12).

In cases where Site Plan approval involves site improvements that cannot be fully completed before the building is ready for use, the Planning Commission may, as circumstances warrant, require a bond or letter of credit to guarantee completion of specific improvements. Such improvements may include landscape elements, vehicular or pedestrian features, or other site-related infrastructure. Alternatively, the occupancy permit(s) for a new building and/or land use may be withheld until all improvements shown on a site plan are made.

800.07 Advertisement of Pending Site Plan Action

Prior to formal consideration of a Site Plan, the Village of New Concord may require that a sign be placed on the subject property that provides a notification to the general public of the pending action on the proposed Site Plan.

800.08 Standards For Review

The Planning Commission shall review the site plan and supporting documents, taking into consideration the reasonable fulfillment of the objectives listed as follows.

- A. Traffic: Convenience and safety of both vehicular and pedestrian movement within the site and in relationship to adjoining ways and properties.

- B. Parking: Provisions for the off street loading and unloading of vehicles incidental to the normal operation of the establishment, adequate parking, adequate lighting, and internal traffic control.
- C. Services: Reasonable demands placed on municipal services and infrastructure.
- D. Pollution Control: Adequacy of methods for sewage and refuse disposal, and the protection from pollution of both surface waters and groundwater. This includes reducing soil erosion both during and after construction.
- E. Nuisances: Protection of abutting properties and area amenities from any undue disturbance caused by excessive or unreasonable noise, smoke, vapors, fumes, dust, odors, glare, storm water runoff, etc.
- F. Existing Vegetation: Minimizing the area over which existing vegetation is to be removed. Where tree removal is required, special attention shall be given to planting of replacement trees.
- G. Amenities: The applicant's efforts to integrate the proposed development into the existing landscape through design features such as vegetative buffers, roadside plantings, and the retention of open space.
- H. Municipal Character: The building setbacks, area and location of parking, architectural compatibility, signage, and landscaping of the development, and how these features harmonize with the surrounding landscape and built environment.
- I. Design Standards. Compliance with any specific Design Standards set forth in the Village Comprehensive Plan, and/or other adopted urban design standards and requirements.

800.09 Enforcement And Time Limits

A bond or other similar performance guarantee may be required to ensure compliance with the plan and stated conditions of approval. Site plan approval issued under this section shall lapse within two (2) years unless a zoning permit is obtained and construction is completed.

800.10 Site Plan Content

A site plan shall include the following data, details, and supporting plans. The number of pages submitted will depend on the proposal's size and complexity. All of the requirements must be met in each plan, with notations explaining the reasons for any omissions. All site plans shall be prepared by a registered professional engineer, architect, or landscape architect. The Zoning Inspector may waive one or several of the following requirements if he or she determines that such items are not necessary to make a determination as to whether the proposed construction, alteration, relocation or change in land use, or other activity is consistent with the standards for review listed above. If, during the review of the Site Plan, the Planning Commission finds that such information is necessary to fully and completely consider such Site Plan, the Planning Commission may require such information before formally considering the proposed Site Plan. Items required for submission include:

- A. Name of the project, boundaries, legal description and location maps showing sites' location in the Village, date, north arrow, and scale of the plan.
- B. Name and address of the owner of record, developer, and seal of the engineer, architect, or landscape architect who prepared the site plan.

- C. Names and addresses of all owners of record of abutting parcels and those within two hundred feet (ft.) of any property line of the subject property.
- D. All existing lot lines, easements, and rights of way. Include area in acres or square feet, abutting land uses, and the location and use of structures within two hundred feet (200 ft.) of the site.
- E. The location and use of all existing and proposed buildings and structures within the proposed development.
- F. All dimensions of height and floor area, showing all exterior entrances, and all anticipated future additions and alterations.
- G. An illustration of traffic movement, ingress and egress, and the location of all present and proposed public and private drives, parking areas, driveways, sidewalks, ramps, curbs, paths, landscaping, walls, and fences.
- H. Location, type, and screening details for all waste disposal containers shall also be shown.
- I. The location, height, intensity, and bulb type (e.g., fluorescent, LED, sodium incandescent) of all external lighting fixtures. The direction of illumination and methods to eliminate glare onto adjoining properties must also be shown.
- J. The location, height, size, materials, and design of all proposed signage.
- K. The location, height, size, materials, and design of all proposed structures.
- L. Plans for fire protection and emergency vehicle movement and access.
- M. The location of all present and proposed utility systems including, sewage or septic systems, water supply system, telephone, cable and electrical systems, storm drainage system including existing and proposed drain lines, culverts, catch basins, headwalls, endwalls, hydrants, manholes, and drainage swales.
- N. All existing natural land features, trees, forest cover, and water sources, and all proposed changes to these features including size and type of plant material. Water sources will include ponds, lakes, streams, wetlands, flood plains, and drainage retention areas.
- O. Zoning for adjacent parcels, including those across the street.
- P. Traffic flow patterns within the site, entrances and exits, loading and unloading areas, curb cuts on the site and within one hundred feet (100 ft.) of the site (including those on opposite sides of a street).
- Q. A pedestrian circulation plan shall also be shown.
- R. Elevation plans at a scale of 1/4" = 1' or 1/8" = 1' for all exterior facades of the proposed structure(s) showing architectural design features and the type and color of materials to be used.
- S. A landscape plan
- T. For larger development projects, the Zoning Inspector may require existing and proposed topography

at a one (1) foot contour intervals. All elevations shall refer to the nearest United States Coastal and Geodetic Bench Mark. If any portion of the parcel is within the 100 year flood plain, the area will be shown and base flood elevations given. Indicate areas within the proposed site and within fifty feet (50 ft.) of the proposed site, where ground removal or filling is required, and give its approximate volume in cubic yards.

800.11 Traffic Impact Study

A traffic impact study may be required by ODOT on State Routes. If a traffic impact study is not required by ODOT, the Village of New Concord may require a Traffic Impact Study in accordance with the following:

- A. A Traffic Impact Study may be required when proposed development would be expected to generate more than one hundred (100) directional trips during the peak hour of generation or five hundred (500) trips in an average day.
- B. Traffic Impact Study may be required for new phases or changes to an existing development where a traffic study is more than two (2) years old and roadway conditions have changed significantly (volumes increasing more than two percent (2%) annually).
- C. Traffic Impact Study may be required for a change or expansion at an existing site where the change or expansion is expected to increase traffic by at least one hundred (100) directional trips in a peak hour or result in at least five hundred (500) additional vehicle trips per day for the entire project.

800.12 Traffic Impact Study Contents

All traffic impact studies shall include the following items:

A description of the site, surroundings, and study area: Illustrations and a narrative shall describe the characteristics of the site and adjacent roadway system (functional classification, lanes, speed limits, etc.). This description shall include surrounding land uses, expected development in the vicinity which could influence future traffic conditions, special site features and a description of any planned roadway improvements. The study shall define and justify the study area selected for analysis.

Description of the proposed development: A description of factors such as the number and types of dwelling units, the gross and usable floor area, the number of employees, and shift change factors. Intended phasing or future expansion shall also be noted.

Description of existing traffic conditions: Existing conditions including existing peak hour traffic volumes (and daily volumes if applicable) on street(s) adjacent to the site. Existing counts and levels of service for intersections in the vicinity, which are expected to be impacted, shall be provided. Traffic count date shall not be more than two (2) years old.

Roadway characteristics shall be described and illustrated, as appropriate. Features to be addressed include land configurations, geometries, signal timing, traffic control devices, posted speed limits, average running speeds, and any sight distance limitations. Existing levels of service shall be calculated for intersections included within the study area. The existing right of way shall be identified along with any planned expansion of the right of way. Existing driveways and potential turning movement conflicts in the vicinity of the site shall be illustrated and described.

Background Traffic Growth: For any project requiring a Traffic Impact Study with a construction completion date beyond one (1) year at the time of the traffic study, the analysis shall also include a scenario analyzing forecast traffic at date of construction completion.

Trip Generation: Forecasted trip generation of the proposed development for the a.m. (if applicable) and p.m.

peak hour and average day shall be calculated. This forecast shall be based on the data and procedures outlined in the most recent edition of Trip Generation published by the Institute of Transportation Engineers (ITE).

Phased Projects: For projects intended to be developed in phases, the trip generation by phase shall be described.

Methodology: A description of the application of standard engineering procedures for determining the distribution shall be attached (trip distribution model, market studies, counts at existing driveways, etc.).

Impact Analysis: Level of service or "capacity" analysis at the proposed access points using the procedures outlined in the most recent edition of the Highway Capacity Manual published by the Transportation Research Board shall be provided. Before and after capacity analyses shall be performed for all street intersections where the expected traffic generated at the site will comprise at least five percent (5%) of the existing intersection capacity.

Access Design/Access Management Standards: The study shall include a map and description of the location and design of proposed access (driveways or new street intersections) including: any sight distance limitations, dimensions from adjacent driveways and intersections within two hundred fifty feet (250 ft.) on either side of the main roadway, data to demonstrate that the number of driveways proposed is the fewest necessary, and support that the access points will provide safe and efficient traffic operation.

Other Study Items: The Traffic Impact Study shall also include the following:

- A. Need for, or provision of, any additional right of way where planned or desired by the applicable transportation agency.
- B. Changes that should be considered to the site plan layout.
- C. If the use involves a drive through facility, the adequacy of the queuing area shall be evaluated.
- D. If a median crossover is desired, separate analysis shall be provided.
- E. If a traffic signal is being requested, the applicable traffic signal warrants shall be provided along with an analysis of traffic progression along the roadway through coordination with other signals.
- F. Description of site circulation and available sight distances at site driveways.
- G. Description of opportunities to define pedestrian circulation to and from the site, and any anticipated impact relative to existing or planned bike/walking trails and/or dedicated bike lanes in roadways. The weight and relative importance of such considerations shall be proportional to the size of the proposed development and proximity of existing or planned bike or walking trails and/or dedicated bike lanes.
- H. The Traffic Impact Study shall outline mitigation measures and demonstrate any changes to the level of service achieved by these measures. Any alternatives or suggested phasing of improvements shall be described. The mitigation measures may include items such as roadway widening, turn lane geometries, changes to signalization, elimination or combination of access points, or reduction in the proposed intensity of use. Any applicable local or State agency shall review proposed mitigation measures. The responsibility for construction and timing of roadway improvements shall be described.
- I. Mitigation/Alternatives: The Traffic Impact Study shall outline mitigation measures and demonstrate any changes to the level of service achieved by these measures. Any alternatives or suggested phasing of improvements shall be described. The mitigation measures may include items such as roadway widening, turn lane geometries, changes to signalization, elimination or combination of access points, or reduction in the proposed intensity of use. Any applicable local

or State agency shall review proposed mitigation measures. The responsibility for construction and timing of roadway improvements shall be described.

- J. Qualifications: Any Traffic Impact Study involving roadway or traffic signal design work shall be prepared by, or under the supervision of, a registered engineer (P.E.) with specific training in traffic engineering. The Traffic Impact Study shall include a resume of the preparer responsible for the report. The Traffic Impact Study may also include relevant experience of the preparer's firm.

800.13 Site Plan Review Criteria and Standards

The following design criteria and standards apply to all construction subject to Site Plan Review pursuant to this Article. In addition, this Zoning Ordinance includes an Overlay Zoning District(s) which includes specific and unique design standards described or referenced therein. All construction subject to Site Plan Review shall meet and any special requirements or standards described in an applicable Overlay Zone, and/or the following general requirements:

- A. The Site Plan shall show that a proper relationship will exist between thoroughfares, service roads, driveways, sidewalks, bike lanes and parking areas to encourage pedestrian, bicyclist and vehicular traffic safety on both public and private lands.
- B. All development features, including the principal buildings, open spaces, service roads, driveways and parking areas, shall be so located to minimize the possibility of adverse effects upon adjacent development.
- C. Building location and placement shall be selected with appropriate consideration given to minimizing the removal of large trees (in accordance with change of topography).
- D. Visual and auditory privacy for surrounding properties and occupants should be achieved with a suitable relationship among buildings, fences and walls, landscaping, topography, and open space.
- E. Parking area landscaping and screening shall channel traffic flow in a safe manner, and on-site traffic circulation shall be designed to provide adequate access for fire and police protection, and minimize interference with the traffic carrying capacity of adjacent streets.
- F. Refuse storage and pick-up facilities shall be indicated on the Site Plan and shall be fenced, screened, or landscaped to prevent blowing or scattering of refuse, and to provide an adequate visual barrier from locations both on- and off-site.
- G. All utilities on-site shall be located underground.
- H. Grading and surface drainage provisions shall be designed to minimize adverse effects on abutting properties, streams, and public streets, and to minimize the possibility of erosion in a manner consistent with the requirements of a Storm Water Pollution Prevention Plan (SWP3).
- I. All private streets, driveways, and parking areas are to be of a useable shape and designed so that lighting from fixed sources and vehicles does not adversely impact surrounding property.
- J. The design of the site and physical structures advances applicable community planning principles expressed in the Comprehensive Plan and any related or area-specific planning documents.
- K. All principal and accessory buildings shall be designed with quality architectural elements with contextual scale, color and materials that will allow a project to blend into its setting and build upon the existing aesthetic identity of an area. Large building mass and long wall planes should be broken up with features such as windows, doors, colors, material variations/patterns and articulation to help provide a sense of human scale.
- L. Main entrances of buildings should connect to a walkway to the street sidewalk. Connecting walkways may cross parking aisles or driveways if distinguished from driving surfaces through the use of durable, low maintenance surface materials such as pavers, bricks, scored concrete or scored and painted asphalt to enhance pedestrian safety and comfort.
- M. Where possible, parking areas shall be distributed around large buildings on not less than two sides in order to shorten the distance to other buildings and public sidewalks and to reduce the perceived scale of paved surfaces.

800.14 Outside Assistance & Expertise

The Village of New Concord may request that applications for Site Plan approval be reviewed by professional planners, engineers or landscape architects to ensure compliance with all code provisions. The costs of securing expert advice or studies shall be borne by the applicant.

800.15 Changes To Site Plans

After the approval of a Site Plan, the developer, individual property owners or property owners wish to make major or minor modifications to site plans. Changes are considered to be either major or minor changes depending on the level of development and redevelopment activity.

A. Minor Site Plan Changes

The Zoning Inspector shall review the proposed modifications and shall determine if the scope of the proposed changes is major or minor in nature. To qualify as a minor modification, the Zoning Inspector shall find that proposed modification consists of only activity that is no more intensive than adjusting the size and location of decks, dumpster locations, patios and required screening, fencing, lighting, landscaping and other similar minor adjustments to the site. Minor modifications are also changes that do not increase in the number of housing units in a structure, or increase building size(s) by more than 25% and do not modify approved circulation drives and parking areas.

Minor modifications can be reviewed and approved by the Zoning Inspector. An application for an "Amendment to an Approved Site plan" shall first be filed with the Zoning Inspector and shall include five copies of revised development plans clearly showing the proposed changes. The Zoning Inspector may approve an amended site plan if he or she finds that such changes are not contrary to any issues raised during the initial review of the site plan, or are contrary to any other requirement of this Zoning Ordinance. The Zoning Inspector may also approve an amended Site Plan with minor modifications subject to conditions. The Planning Commission shall be advised of all minor changes authorized under the above procedures.

B. Major Site Plan Changes.

Major Changes to Site Plans (those that do not meet the requirements above) shall be resubmitted as a new Site Plan.

ARTICLE IX SIGNS AND OUTDOOR ADVERTISING STRUCTURES

900.01 Statement of Purpose

The purpose of this Article is to create the legal framework for a comprehensive but balanced system of street signage, and thereby to facilitate an easy and pleasant communication between people and their environment. With this purpose in mind, it is the intention of this ordinance to authorize the use of street signage that is:

- A. Compatible with the surroundings;
- B. Appropriate to the type of activity to which it pertains;
- C. Expressive of the identity of individual proprietors and of the community as a whole; and
- D. Legible in the circumstances in which it is seen.

900.02 Permits and Fees

No person shall erect, repair, alter, relocate or maintain within the Village any sign or other advertising structure except those exempted in subsection (g) hereof without first obtaining a sign permit from the Zoning Inspector and making payment of the fee required by subsection (d) hereof, except that repairs or maintenance may be permitted without first obtaining a permit.

900.03 Application for Permit

Applications for sign permits shall be made upon forms provided by the Zoning Inspector and shall contain or have attached thereto the following information:

- A. The name, address and telephone number of the applicant and owner of the premises;
- B. The location of the building, structure or lot to which or upon which the sign or other advertising structure is to be attached or erected;
- C. The position of the sign or other advertising structure in relation to nearby buildings or structures and a site plan for ground signs;
- D. Scale drawings including: graphics, colors, plans and specifications, the method of construction and attachment to the building or the method of installation in the ground, using a scale of one inch equaling one foot, or another standard architectural scale;
- E. The name of the person erecting the structure;
- F. Written consent of the owner of the building, structure or land to which or on which the structure is to be erected;
- G. The product, use or service to be advertised;
- H. Such other information as the Zoning Inspector shall require to show full compliance with this and all other ordinances of the Village.

900.04 Referral of Application to Design Review Board and Issuance of Permit

It shall be the duty of the Zoning Inspector, upon receiving an application for a sign permit, to examine such plans and specifications and other data, and the premises upon which it is proposed to erect the sign or other advertising structure. If it appears that a certificate of appropriateness is required pursuant to Section 407.2, the application shall be referred to the Design Review Board. If approved by the Design Review Board, the

application shall be returned to the Zoning Inspector who shall then issue the permit. If the work authorized under a sign permit has not been completed within six (6) months after date of issuance, or should the approved plan be altered, the permit shall become null and void.

900.05 Permit Fees

Every applicant, before being granted a sign permit, shall pay to the Village a permit fee in an amount consistent with a resolution passed by Village Council.

900.06 Revocability of Permits

All rights and privileges acquired under the provisions of this chapter or any amendment hereof are mere licenses granted for the duration of the requested use only, and are revocable any time by the Zoning Inspector and all permits shall contain this provision. All permits are conditioned upon the continued use of the premises, or business for the purpose set forth in the application for the permit.

900.07 Authority to Revoke

The Zoning Inspector is hereby authorized to revoke any permit issued by him upon failure of the holder thereof to comply with any provisions of this chapter.

900.08 Permit Exemptions

The permit provisions of this Section shall not apply to the following signs; such signs, however, are still subject to all other regulations provided for in this chapter:

- A. Non-illuminated real estate signs not exceeding six square feet in area that advertise the sale, rental or lease of the premises upon which such signs are located;
- B. Non-illuminated signs not exceeding twenty square feet in area which advertise the sale or development of lot subdivisions containing an area of not less than seven lots, erected upon the property so developed and advertised for sale;
- C. Nameplates not exceeding two square feet in area, containing only the name of the residents, the title of the person practicing a profession, the name of the building or property, the name of the agent and the hours and days of operation;
- D. Bulletin boards not exceeding fifteen square feet in area erected upon the premises of a place of worship, funeral home or public institution for displaying the name of the institution and its activities or services;
- E. Signs denoting the location of and direction to public institutions, i.e., churches, schools, etc., shall be affixed to the appropriate municipal street sign;
- F. Signs denoting the architect, engineer or contractor when placed upon work under construction, and not exceeding twelve square feet in area;
- G. Memorial signs or tablets, name of buildings and dates of erection, provided that such signs do not exceed two square feet in area;
- H. Traffic or other Municipal signs, legal notices, railroad crossing signs, danger and such temporary, emergency or nonadvertising signs as may be approved by Council;
- I. Interior signs that are not in the window showcase;
- J. Temporary signs not to exceed 120 days in one calendar year.

900.09 Construction

All signs, canopies, attachments and accessories shall be attached and constructed in safe, secure manner, free of any hazards and it shall be the responsibility of the owners and/or contractor to construct and maintain all signs as required by the State Building Code.

900.10 Wall Signs

Wall signs shall be permitted subject to Section 708 and subject to the following limitations and requirements:

- A. Wall Openings: No wall sign shall cover, wholly or partially, any wall opening.
- B. Projection from Building: No wall sign shall project beyond the ends or top of the building wall to which it is attached, nor be set out more than one foot from the face of the building to which it is attached.
- C. Graphic Display: The graphic display shall not exceed twenty-five percent of the signable wall area, nor shall it exceed 48 inches in height.
- D. Lighting: Lighting shall be permitted on wall signs, provided that illumination is concentrated upon the area of the sign to prevent glare upon the street or adjacent property.
- E. Obstructions to Doors, Windows or Fire Escapes: No wall sign shall be erected, relocated or maintained to prevent free entrance to, or exit from, any door, window or fire escape.

900.11 Projecting Signs

Projecting signs shall be permitted in non-residential districts subject to the following limitations and requirements:

- A. Size Limitations: A projecting sign shall be limited in area to not more than twelve square feet for each face. However, an additional three-inch border or frame may be permitted to provide ornamental design. The maximum horizontal dimension of the sign shall be four and one-half feet.
- B. Projection Over Public Property: Every projecting sign shall be placed so that its lowest point shall be at least eight feet above the public sidewalk over which it is erected, and at a distance not greater than two feet from the face of the wall to which it is attached, measuring from the point of the sign nearest thereto, nor shall any sign or part thereof extend nearer the curb line than one foot.
- C. Obstructions to Doors, Windows or Fire Escapes: No projecting sign shall be erected, relocated or maintained to prevent free entrance to, or exit from, any door, window or fire escape.
- D. Lighting: Lighting shall be permitted on projecting signs, provided that illumination is concentrated upon the area of the sign so as to prevent glare upon the street or adjacent property.

900.12 Ground, Free Standing and Expressway Signs

Ground signs shall be permitted subject to Section 708 and subject to the following limitations and requirements:

- A. Location: In B-2 zoning districts, ground and free standing signs shall be a maximum twelve (12) square feet and shall be set back a minimum of twenty-four (24) inches from the inside of the curb to the front edge of any portion of the sign and shall not be located within 6 feet of any tree, driveway, street light or traffic sign in the tree lawn. In all other districts, a ground free standing sign shall not be permitted in any right-of-way or at any location, which in the opinion of the zoning inspector, will block sight distances and cause a hazard for vehicular traffic or pedestrians.
- B. Size Limitation: Outside B-2 District where free standing signs are permitted, no free standing signs shall exceed fifty (50) square feet, nor shall free standing signs exceed twenty (20) feet from ground level to its top most point. The minimum clearance under such signs shall be eight (8) feet when over areas used by pedestrians, and where possible free standing signs shall be centered on the lot.

900.13 Expressway Signs

One expressway sign per property may be located when within 1,500 feet of the Interstate 70 right-of-way if approved as a conditional use by the Planning Commission under Section 1000.3. The maximum height of

expressway signs shall be 40 feet and maximum area shall be 200 square feet. The lighting, materials and orientation of the sign shall be approved as part of the conditional use.

- A. Lighting: Lighting shall be permitted on ground, free standing and expressway signs, provided that illumination is concentrated upon the area of the sign so as to prevent glare upon the street or adjacent property.
- B. Multiple Tenant Signs: Wall signs in compliance with the requirements of "Signage" in Section 411.2 may be permitted to display signs for multiple tenants in B1 and B3 districts on one property or business provided that the total aggregate area of the signage including any permitted message board shall also comply with Section 708.

900.14 Awnings and Canopies

- A. Setback from Curb Lines: No awning or canopy shall be permitted to extend beyond a point twelve inches inside the curb line.
- B. Height above Sidewalk; Awnings and Canopies: All awnings and canopies shall be constructed and erected so that the lowest portion thereof is not less than eight feet above the level of the sidewalk.
- C. Construction of Awnings: Awnings shall be constructed of cloth or other fabric. However, all frames and supports shall be of metal. Every awning shall be securely attached to and supported by the building. Posts or columns beyond the building lines shall not be permitted for awnings. Each awning shall be attached according to recognized engineering practices.
- D. Advertising: No advertising shall be placed on any awning or canopy, except that the name of the owner and the business, industry or pursuit conducted within the premises may be painted or otherwise permanently placed in a space not exceeding eight inches in height on the front and side portions thereof. Any advertising space used on an awning or canopy shall be considered as part of the total permitted signage for a building or structure.

900.15 Signs in Residential Districts

- A. Garage Sale Signs are permitted provided that no such sign is larger than three (3) square feet in area; that only two (2) such signs exist on other than the seller's property; that the location of such signs is given the Zoning Inspector forty-eight (48) hours before their placement; that such signs are kept on display forty-eight (48) hours or less; and that no property so advertise more than twice a year. No permit fee will be required under these conditions.
- B. Nonilluminated announcement or professional signs are permitted, provided that such signs are limited to one (1) per structure, and that such signs are not more than two (2) square feet in area.
- C. A window sign erected within a structure is allowed as long as only twenty-five (25) percent or less of the area of the window is obscured by such sign.

900.16 Signs Prohibited

- A. Animated Signs: No flashing, moving or animated signs shall be erected or constructed or maintained in the Municipality.
- B. Roof Signs: No roof signs shall be erected or constructed in the Municipality.
- C. Billboards: No billboards or off-premise signs shall be erected or constructed in the Municipality.
- D. Marquee Signs: No marquee signs shall be erected, constructed or maintained within the Municipality.
- E. Real Estate Sold Signs: No real estate signs announcing that the premises upon which such signs

are located have already been sold, rented or leased shall be erected or constructed within the Municipality, for no longer than a thirty day period.

- F. Illumination: Interior illumination of signs, and signs whose characters, letters, figures, designs or outline are illuminated by electric lights or luminous tubes as part of the sign shall not be permitted.
- G. Mobile Signs: No mobile signs on wheels, runners, casters, parked trailers, parked vehicles or other mobile devices shall be permitted within the village (except those on commercial delivery and service vehicles).
- H. Temporary Signs: No temporary signs shall be permitted on any premises unless specifically permitted herein.
- I. Materials: No plastic signs shall be constructed or erected in the Village.

900.17 Maximum Number and Size of Signs Permitted Within each Zoning District

A maximum of two of the four types of signs, wall, and ground, projecting and free standing, may be permitted subject to the following limitations:

Zoning District	Types of Signs Permitted	Maximum Sign Area (All Signs)
S-1	Wall, Ground	1/2 square feet of sign per lineal feet of road frontage up to a maximum of 50 square feet.
O-1	Wall, Ground, Free Standing	1 square feet of sign area per lineal feet of road frontage up to a maximum of 100 square feet
B-1	Wall, Ground, Free Standing, Projecting	2 square feet of sign area per lineal feet of road frontage up to a maximum of 100 square feet.
B-2	Wall, Ground, Free Standing, Projecting	2 square feet of sign area per lineal feet of road frontage up to a maximum of 100 square feet.
B-3	Wall, Ground, Free Standing, Expressway ⁽¹⁾	4 square feet of sign area per lineal feet of road frontage up to a maximum of 300 square feet.
I-1	Wall, Ground, Free Standing	3 square feet of sign area per lineal feet of road frontage up to a maximum of 300 square feet.

(1) If approved as a conditional use. Expressway signs when permitted as a conditional use shall not be counted toward the maximum area or number of signs.

900.18 General Provisions

- A. Signs Not to Constitute a Traffic Hazard: No sign or other advertising structure as regulated by any of the provisions of this chapter shall be erected at the intersection of any streets in such a manner as to obstruct free and clear vision; or at any location where, by reason of the position, shape or color, it may interfere with, obstruct the view of, or be confused with, and authorized traffic sign, signal or device; which makes use of the words "STOP", "LOOK", "DRIVE-IN", or any other word, phrase, symbol or character in such a manner as to interfere with, mislead or confuse traffic.
- B. Advertising Matter: Only the type of business, services offered, and the name of the owner, proprietor or the manager of the place of business erecting and maintaining such sign shall be permitted as advertising matter. Graphics referring to name brand products sold on the premises

may occupy a maximum of 20% of the sign area.

900.19 Temporary Signs

Temporary window signs may be used for special events, but shall not be used for more than 30 consecutive days, shall only be permitted on the interior of buildings, shall be subject to the requirements of Section 410, and may not exceed 50% of any window area.

Temporary cloth signs, banners, streamers, etc., may be suspended over public property by special permission of Council. The purpose of such temporary signs shall be for civic or community affairs of a public or semipublic nature and not for private gain. A surety bond in an amount as may be determined by Council and conditioned on the faithful observance of the provisions of this chapter, and which shall indemnify and save harmless the Municipality from any and all judgments, costs or expenses which the Municipality may incur or suffer by permitting the erection of any temporary sign as hereinbefore mentioned, may be required by Council from the person designing to erect or suspend such temporary sign. Alternatively, Council may require a liability insurance policy, issued by an insurance company authorized to do business in the State, in lieu of such bond.

900.20 Removal of Certain Signs

Any sign now or hereafter existing which no longer advertises a bona fide business conducted upon the premises or no longer serves the purpose for which it was intended, shall be taken down and removed by the owner, agent or person having the beneficial use of the building or structure upon which such sign may be found, within ten days after written notification from the Zoning Inspector.

Notice shall be given by registered mail to the latest permit holder or to the property owner, or to such owner's spouse or agent, or to the person otherwise in charge of such sign or premises. In the event no such named person may be found or, when deemed proper by the Zoning Inspector, the sign or premises shall be posted with the notice to remove.

Upon failure to comply with such notice within the time specified in such order, the Zoning Inspector is hereby authorized to cause removal of such sign, and any expense incident thereto shall be paid by the owner of the building to which such sign is attached, which costs shall become a lien upon the property until paid.

Failure to remove sign pursuant to a proper order shall be a violation of the Zoning Code subject to the penalties set forth in Section 901.

900.21 Unsafe and Unlawful Signs

If the Zoning Inspector finds that any sign or other advertising structure regulated herein is unsafe or insecure, or is a menace to the public, or has been constructed or erected or is being maintained in violation of any of the provisions of this chapter, notice shall be given in writing by the Zoning Inspector to the permitted thereof. If the permitted fails to remove or alter the structure to comply with the standards herein set forth within ten days after such notice, such sign or other advertising structure may be removed or altered to comply by Zoning Inspector at the expense of the permitted or owner of the property upon which it is located. The Zoning Inspector shall refuse to issue a permit to any permitted or owner who refuses to pay costs so assessed. The Zoning Inspector may cause any sign or other advertising structure that is an immediate peril; to persons or property to be removed summarily and without notice.

900.22 Annual Inspection

The Zoning Inspector shall inspect annually, or at such other times as are necessary, each sign or other advertising structure regulated by this chapter for the purpose of ascertaining whether the same is secure or

insecure, and whether it is in need of removal or repair.

900.23 Maintenance

The owner of any sign regulated by this chapter is hereby required to properly maintain in good condition and repair all parts and supports of the sign.

900.24 Presumption of Responsibility

The occupant of any premises upon which a violation of any of the provisions of this chapter is apparent or the owner of any sign placed or remaining anywhere in violation of any of the provisions of this chapter shall be deemed prima-facie responsible for the violation so evidenced and subject to the penalty provided therefore.

900.25 Nonconforming Existing Signs

Every sign or other advertising structure lawfully in existence on the effective date of this ordinance, shall not be replaced, altered or relocated, except as such may be required by law or resolution, unless it is made to comply with the provisions of this chapter, except that existing non-conforming off-premise signs may be repaired or replaced without increasing the size or height at an existing location and setback when in compliance with the Ohio Revised Code and all traffic laws. Repair, replacement and maintenance of all existing off-premise signs shall be the responsibility of the sign owner(s). Repair or replacement of said signs shall require a Zoning Permit and the design of any change shall be approved by the Design Review Board if located on Main Street (U. S. Route 40). Village Council may approve additional off-premise signs for directional purposes when necessary for traffic safety.

900.26 Temporary Signs - General

- A. No more than one off premise real estate sign is permitted on any lot or property at any time.
- B. One on-premises real estate sign promoting the sale of any continuous parcel containing more than 2 acres in a commercial district may be permitted up to 32 square feet. All other real estate sale signs shall be six square feet or less.
- C. In addition to the above standards, signage for any village or community sponsored events placed in the right-of-way, including streets or other village property may not contain any promotion for a commercial product or business.
- D. Decorations promoting religious or other similar special events are exempt from these requirements. Exempt decorations may not include lettering or other logos promoting a commercial product, event or business.

900.27 Commercial Temporary Signs

Temporary signs as defined herein, excluding those signs approved by Village Council for community or non-profit purposes, shall not be used or displayed for more than 31 consecutive days. Any temporary sign used or displayed for any period may not be used or displayed again for the same business or premises until a 28 day period has elapsed. However, different temporary signage may be used or displayed in compliance with the requirements. The effect of the above being, that temporary signage may be used periodically or rotated for special occasions or sales. No commercial temporary sign shall be used, erected or displayed in any street, alley or right of way at any time. One temporary sign per calendar year in compliance with all requirements herein any promote an off-premise business or merchandise.

The total aggregate area of temporary signs on any lot parcel or property or for any business at any time shall not exceed the following limits.

O-1	1 Square foot of sign area per every 20 feet of road frontage up to maximum of 16 square feet.
B-1	1 Square foot of sign area per every 20 feet of road frontage up to a maximum of 16 square feet.
B-2	1 Square foot of sign area per every 10 feet of road frontage up to a maximum of 32 square feet.
B-3	1 Square foot of sign area per every 10 feet of road frontage up to a maximum of 32 square feet.
I-1	1 Square foot of sign area per every 10 feet of road frontage up to a maximum of 32 square feet.

900.28 Standards for All Temporary Signs

- A. No temporary signs may be externally or internally lighted.
- B. No temporary signs may use removable lettering or be portable.
- C. No temporary signs may be placed on any property without the express consent of the property owner.
- D. No temporary signs may be attached to any village utility post or utility pole, light post, trees or other natural vegetation, permanent sign or sign post.
- A. Non-commercial signs only measuring less than 4 square feet in area and measuring less than 30 inches high from street level may be placed in the right of way in areas that do not cause any hazard or interference with pedestrian or vehicular movement.
- B. The owner and/or erector of any sign shall be liable for any loss or accident caused by said sign.

900.29 Vending Machines

Vending machines, which include any sign as defined in the zoning code, are considered “signage” and shall require a sign permit. Vending machines (including telephones) that contain signage shall adhere to the requirements herein and shall not be placed in any right of way.

900.30 Nonprofit Promotional Signs.

Business promotional signs for the purpose of supporting schools, colleges, non-profit entities and government institutions may be erected or placed on athletic field property occupied by the non-profit entity under the following conditions:

- A. No sign shall exceed 32 square feet in area.
- B. No sign shall exceed 12 feet above ground level.
- C. No sign shall be within 100 feet of any public street or road.
- D. There shall be a maximum four feet spacing between signs.
- E. Signs cannot be erected more than 14 days before the season and shall be removed within 14 days of the season ending on the field where signs are located.
- F. All signs shall be maintained in a good, clean, safe condition with no faded, chipped or discolored paint.
- G. A Zoning Permit is required annually for each field. The fee shall be equal to one sign permit fee.
- H. Banners may only be used in compliance with regulations regarding temporary signs.
- I. All signs shall comply with requirements not specifically exempted by this chapter.
- J. All signs shall be oriented toward a game field.

900.31 LED and Digital Signs

Digital or LED display signs shall be permitted under the following conditions:

- A. The sign shall be permitted only as a fully enclosed section of a permanent wall sign constructed of brick, stone, or concrete. The sign and wall shall be surrounded by approved landscaping that measures 10 times the area of the lighted area of the sign (one side). For example, a 16 sq. ft. sign would require a 160 sq. ft. landscaped area. The landscaped area shall be properly maintained or the sign permit shall be revoked.
- B. No flashing or moving lights, animation or video shall be displayed at any time.
- C. The total internally lighted area shall have black background and shall not exceed 16 square feet in area.
- D. The sign display may not be changed more than two times each hour.
- E. The display shall only be lighted or turned on during open business hours.
- F. LED signs shall comply with all other requirements of the code including size, number, height and location of signs.
- G. Lighting levels shall be consistent with Section 900.32.

900.32 Lighting:

Signs (excluding temporary signs) may be illuminated to 0.3 foot candles above ambient light conditions when measured at the distances identified hereunder: The source of illumination upon a sign shall be shielded from traffic and adjacent properties and shall not be visible beyond the property line of the parcel on which the lighted sign is located. This requirement shall not apply in the case of the use of bare bulbs in association with changeable copy and theater marquee signs.

AREA OF SIGN sq. ft.	MEASUREMENT Distance (ft.)
10	32
15	39
20	45
25	50
30	55
35	59
40	63
45	67
50	71
55	74
60	77
65	81
70	84
75	87
80	89
85	92
90	95
95	97
100	100

ARTICLE X NONCONFORMITIES

1000.01 Continuance of Nonconforming Uses

Any lawful use of buildings or land existing at the effective date of this ordinance may be continued, even though such use does not conform to the provisions hereof. The nonconforming use of a building may be extended throughout those existing parts of the building that were arranged or designed for such use.

1000.02 Expansion or Enlargement of Nonconforming Uses

No nonconforming building or structure shall be moved, extended, enlarged, or altered and no nonconforming use of land shall be expanded, except when authorized by the Planning Commission according to the provisions of Section 1003.1.

1000.03 Discontinuance of Nonconforming Uses

A nonconforming use which is discontinued for a period of one (1) year shall not again be used except in conformity with the regulations of the district in which it is located.

1000.04 Reconstruction of Nonconforming Uses

A nonconforming use which has been damaged by fire, explosion, act of God or the public enemy to the extent of sixty (60) percent or more of its reproduction value at the time of damage shall not be restored except in conformity with the regulations of the district in which it is located. When damaged by less than sixty (60) percent of its reproduction value, a nonconforming use may be repaired or reconstructed, and used as before the time of the damage, provided such repairs or reconstruction are started within one (1) year of the date of such damage.

1000.05 Nonconforming Mobile Homes

A nonconforming trailer or mobile home located on a lot (outside a manufactured home park) in any district, once removed, shall not be relocated on such lot unless the unit was "traded-in" for another unit which meets the definition of a manufactured home as defined herein. In this instance, the replacement shall be on site within thirty (30) days of the removal of the previous unit and must meet all yard requirements.

1000.06 Nonconforming Uses Under Construction

Any building arranged, intended or designed for a nonconforming use, the construction of which is started at the time of the passage of this ordinance, may be completed and put into such nonconforming use within one (1) year after this ordinance, or any amendment hereto takes effect.

1000.07 Change of Nonconforming Uses

An existing nonconforming use may be changed to another nonconforming use provided that no structural alterations are made (except as specifically required by enforcement of other codes and regulations), and provided that prior approval is granted by the Planning Commission according to Section 1003. In considering such a change, the Planning Commission may require specific conditions and additional development standards to minimize adverse impacts to adjoining property. The new use must meet all parking requirements.

1000.08 Continuance of Nonconforming Structures

Where a lawful structure exists at the time of the effective date of this ordinance, or any amendment hereto that could not be built under the terms of this Ordinance because of regulations on building size, lot coverage, height, yard requirements, or similar dimensional requirements, such structure may be continued so long as it remains otherwise lawful, subject to the following provisions:

- A. No such non-conforming structure may be enlarged or altered in a way which increases its non-conformity, but any structure or portion thereof may be altered to decrease its non-conformity.
- B. When a non-conforming structure has been damaged by fire, explosion, act of God or the public enemy to the extent that sixty (60) percent or more of its reproduction value is lost, then such non-conforming structure may only be repaired or reconstructed according to the requirements of this Ordinance.
- C. Should a nonconforming structure be moved for any reason, it shall thereafter conform to the regulation for the district in which it is located after it has moved.

1000.09 Nonconforming Lots of Record

- A. **Single Non-conforming Lots of Record:** In any district in which single-family dwellings are permitted, a single-family dwelling and customary accessory buildings may be erected on any single lot of record at the effective date of adoption or amendment of this Ordinance, notwithstanding limitations imposed by other provisions of this Ordinance. Such lot must be in separate ownership and not of continuous frontage with other lots in the same ownership. This provision shall apply even though such lot fails to meet the requirements for area or width, or both, that are generally applicable in the district, provided that yard dimensions and requirements other than those applying to area or width, or both, of the lot shall conform to the regulations for the district in which such lot is located. Variances from requirements other than lot area or lot width shall be obtained only through action of the Board of Zoning Appeals as provided in Section 1004.
- B. **Non-Conforming Lots of Record in Combination:** If two or more lots or a combination of lots and portions of lots with continuous frontage in single ownership are of record at the time of passage or amendment of this Ordinance, and if all or part of the lots with no buildings do not meet the requirements established for lot width and area, the lands involved shall be considered an undivided parcel for the purposes of this Ordinance, and no portion of said parcel shall be used or sold in a manner that diminishes compliance with lot width and area requirements established by this Ordinance, nor shall any division of any parcel be made which creates a lot with a width or area below the requirements stated in this Ordinance.

1000.10 Nonconforming Signs

Any lawful sign existing and being used and maintained by an active entity at the effective date of this ordinance may continue even though it does not conform to the provision hereof. Any nonconforming sign requiring a permit including a change of use of the property shall be made to comply with the provisions of this ordinance.

ARTICLE X I ENFORCEMENT

1100.01 Zoning Certificates Required

It shall be unlawful for an owner to use or permit the use of any structure, building or land, or part thereof, hereafter created, erected, changed, converted or enlarged, wholly or partly, until a zoning certificate is issued by the Zoning Inspector. It shall be the duty of the Zoning Inspector to issue a certificate, provided he is satisfied that the structure, building or premises and the proposed use thereof conform with all the requirements of this ordinance. No permit for excavation, construction or reconstruction shall be issued by the Zoning Inspector unless the plans, specifications and the intended use conform to the provisions of this ordinance.

A zoning certificate shall be required for any of the following, except as herein provided.

- A. Construction or structural alteration of any building, including accessory buildings.
- B. Change in use of an existing building or accessory building to a use of a different classification.
- C. Conversion of any building into a dwelling or the conversion of any dwellings so as to accommodate an increased number of dwelling units or families.
- D. Occupancy and use of vacant land.
- E. Change in the use of land to a use of a different classification.
- F. Any change in the use of a nonconforming use.
- G. All lawful nonconforming uses of land or buildings created by adoption of this ordinance or any amendment thereto.
- H. Construction/establishment of a parking area.

1100.02 Zoning Certificates For Existing Uses Which May Be Nonconforming.

Upon written request from the owner or tenant, the Zoning Inspector shall issue a zoning certificate for any building or premises existing at the time of enactment of this ordinance that certifies, after inspection, the extent and kind of use made of the building and premises and whether such use conforms to the provisions of this ordinance. No charge shall be made for issuing zoning certificate in accordance with this paragraph.

1100.03 Application and Issuance of Zoning Certificates

Written application shall be made for a zoning certificate for the construction of a new building or the alteration of an existing building. Said certificate shall be issued within ten (10) working days after a complete written request for the same has been made to the Zoning Inspector or his agent, provided such construction or alteration is in conformity with the provisions of this ordinance.

Every application for a zoning certificate shall be accompanied by a plan in duplicate and such other plans as may be necessary to show the location and type of buildings to be erected or alterations to be made. Where construction or physical improvement of the land is involved, the lot and location of the buildings to be built thereon shall be staked out on the ground before construction is started, and all dimensions shown on filed plans shall be true. Each plan shall show:

- A. The street providing access to the lot and the exact location of the lot in relation to the nearest cross street.
- B. The name of the plan, if any, and the lot numbers of the abutting properties.

- C. The actual dimensions of the lot, the yard and other open space dimensions thereof, and the location and size of any existing structure thereon.
- D. The location and size of the proposed structure and/or the proposed enlargement of the existing structure.
- E. Any other information that, in the judgment of the Zoning Inspector, may be necessary to enforce this ordinance.

The Zoning Inspector shall not issue a zoning certificate for any application requiring site plan review by the Planning Commission, unless the proposed site plan has been approved by the Commission. The Zoning Inspector also shall not issue a zoning certificate for any application requiring a certificate of appropriateness from the Design Review Board according to Section 407.

1100.04 Fees for Zoning Certificates

A fee, according to a resolution passed by Village Council, shall accompany each application for a zoning certificate. The Zoning Inspector shall be responsible for collection and deposit of all fees for credit to the general revenue fund of the municipality.

1100.05 Zoning Certificate Records

A record of all zoning certificates shall be kept on file in the office of the Zoning Inspector or his agent, and copies shall be furnished upon request to any person having proprietary or tenancy interest in the building or land affected.

1100.06 Violations -- Penalties

It shall be unlawful to locate, erect, construct, reconstruct, enlarge, change, maintain or use any building or land in violation of any regulation in or any provisions of this ordinance or any amendment or supplement thereto as adopted by the Council. Any person, firm or corporation violating any regulation thereto shall be deemed guilty of a misdemeanor, and upon conviction thereof, shall be fined not more than one hundred dollars (\$100.00). Each day during which such illegal location, erection, construction, reconstruction, enlargement, change, maintenance, or use continues may be deemed a separate offense.

1100.07 Remedies

Any certificate issued upon a false statement of any fact which is material to the issuance thereof shall be void. Whenever the fact of such false statements shall be established to the satisfaction of the Council, the certificate shall be revoked by notice in writing to be delivered to the holder of the void certificate upon the premises concerned or if such holders be not found there, by posting the said notice of revocation in some conspicuous place upon the said premises. Any person who shall proceed thereafter with such work or use without having obtained a new certificate according to this ordinance shall be deemed guilty of violation thereof.

In case any building is or is proposed to be located, erected, constructed, reconstructed, enlarged, changed, maintained or used or any land is or is proposed to be used in violation of this ordinance or any amendment or supplement thereto, the Zoning Inspector, Solicitor, or any adjacent or neighboring property owner who would be specially damaged by such violation, in addition to other remedies provided by law, may institute injunction, mandates, abatement, or any other appropriate action, actions, proceeding, or proceedings to prevent, enjoin, abate or remove such unlawful location, erection, construction, reconstruction, enlargement, change, maintenance or use.

1100.08 Zoning Inspector

It shall be the duty of the Zoning Inspector, who shall be appointed by the Mayor, to enforce this ordinance. It shall also be the duty of all officials and employees of the municipality to help the Zoning Inspector by reporting to him upon new construction, reconstruction, or land uses or upon seeming violations. An appeal from the decision of the Zoning Inspector may be made to the Board of Appeals, as provided in Article X.

ARTICLE XII PLANNING COMMISSION

1200.01 Establishment and Organization of The Planning Commission

The New Concord Village Planning Commission is established and organized pursuant to Ordinance K-2-68.

1200.02 Powers and Duties

With respect to the administration of this Ordinance, the Planning Commission has the following responsibilities:

- A. To initiate proposed amendments to this Ordinance according to Article XI
- B. To review proposed amendments to this Ordinance according to Article XI
- C. To review and act upon site plans submitted pursuant to Section 600.8
- D. To review and act upon development plans and applications for PUD zoning classification according to Section 406.
- E. To review and act upon applications for conditional uses
- F. To review and act upon changes to non-conforming uses according to section 800.7.

1200.03 Review of Conditional Uses

Within zoning districts there may be uses listed as conditional. The Planning Commission shall have the power to decide applications for conditional uses in those cases specified in this ordinance. In considering such applications, the Planning Commission shall give due regard to the nature and condition of all adjacent uses and structures and may impose such requirements and conditions as the Planning Commission may deem necessary for the protection of adjacent properties and the public interest, which includes additional landscaping, screening, buffering, or other site design modifications. To approve a conditional use, the Planning Commission must find that all of the following conditions are true:

- A. That the proposed use is in fact listed as conditional use in the zoning district
- B. That the proposed use will be designed, constructed, operated, and maintained to be harmonious and appropriate in appearance with the existing or intended character of the general vicinity.
- C. That the proposed use will not be hazardous or disturbing to existing or future neighboring uses.
- D. That the proposed use would be served adequately by essential public services such as highways, police and fire, drainage, refuse disposal, water and sewer, or schools.
- E. That the proposed use will not create excessive additional requirements at public cost for facilities or services.
- F. That the proposed use will not involve activities, processes, materials, equipment, or conditions of operation that would be detrimental to the neighborhood because of excessive traffic, noise, smoke, or odors.
- G. That the proposed use will not have vehicular approaches to the property that will create interference with traffic movement.
- H. That the proposed use will not result in destruction or damage of natural or historic features of major importance.

1200.04 Expiration of Conditional Uses

Approval of a conditional use shall be deemed to authorize only one particular conditional use. Such approval

shall expire if such use has not been instituted in one year or if discontinued for more than two (2) years.

1200.05 Hearings & Rules

The hearings of the Planning Commission shall be public. However, they may go into executive session for discussion according to applicable laws, but not for vote on any case before it. The Planning Commission shall adopt from time to time such rules and regulations as it may deem necessary to effectuate the provisions of this ordinance.

1200.06 Minutes and Records

The Planning Commission shall keep minutes of its proceedings, showing the vote of each member upon each question or, if absent or failing to vote, indicating such fact, and shall keep records of its examinations and other official actions, all of which shall be immediately filed in the Office of the Clerk and shall be a public record.

1200.07 Witnesses & Oaths

The Planning Commission shall have the power to subpoena witnesses, administer oaths, and punish for contempt, and may require the production of documents under such regulations as it may establish.

1200.08 Notification of Site Plan Review

The Planning Commission shall notify owners of any property within 200 feet of any area applying for site plan review as required by this ordinance by regular mail at least ten (10) days prior to the hearing.

ARTICLE XIII BOARD OF ZONING APPEALS

1300.01 Establishment & Appointment Of Board of Zoning Appeals Members

A Board of Zoning Appeals is hereby established which shall consist of five (5) electors appointed by the Mayor. The Mayor shall choose a successor to fill any vacancy. The five (5) electors first appointed shall serve for terms of one (1), two (2), three (3), four (4), and five (5) years, respectively; thereafter appointments shall be for five (5) year terms, beginning January 1st. Each member shall serve until his successor is appointed and qualified. Vacancies shall be filled by the Mayor and shall be for the respective unexpired term. The members of the Board of Zoning Appeals may receive such compensation as the Council provides.

1300.02 Hearings & Rules

The hearings of the Board of Zoning Appeals shall be public. However, the Board may go into executive session for discussion according to applicable laws, but not for vote on any case before it. The Board shall organize annually and elect a president, vice president and secretary. The Board shall adopt from time to time such rules and regulations as it may deem necessary to effectuate the provisions of this ordinance.

1300.03 Minutes and Records

The Board shall keep minutes of its proceedings, showing the vote of each member upon each question or, if absent or failing to vote, indicating such fact, and shall keep records of its examinations and other official actions, all of which shall be immediately filed in the office of the Clerk and shall be a public record.

1300.04 Witnesses & Oaths

The Board shall have the power to subpoena witnesses, administer oaths, and punish for contempt, and may require the production of documents under such regulations as it may establish.

1300.05 Powers and Duties

The Board of Zoning Appeals shall have the following powers and it shall be its duty:

- A. To hear and decide appeals where it is alleged there is error of law in any order, requirement, decision or determination made by the Zoning Inspector in the enforcement of this ordinance or any amendments thereto. The Board shall also interpret provisions of this ordinance as needed to carry out the purpose and intent of this ordinance. This includes interpretation of the Zoning District Map of New Concord when and if questions arise as to the boundaries of zoning districts.
- B. To consider variances from the dimensional and measurable standards of this Ordinance where it alleged that the special and unique circumstances create conditions where the literal enforcement of such standards will create an unnecessary hardship.

1300.06 Department Assistance

The Board may call upon the various officials and employees of the municipality for assistance in the performance of its duties and it shall be the duty of such departments to render such assistance to the Board as may reasonably be required.

1300.07 Applications

An application, in a case in which the Board has original jurisdiction under the provisions of this ordinance, may be taken by any person aggrieved, including a tenant, or by a governmental officer, department, board or bureau. Such application shall be filed with the Zoning Inspector who shall transmit same to the Board. A fee shall be charged for applications in an amount consistent with a resolution adopted by the Village Council.

1300.08 Hearings & Notification

The Board shall fix a reasonable time for a hearing of a matter to come before it, and shall give at least ten (10) days public notice thereof in a newspaper of general circulation in the municipality and at least ten a (10) day notice to parties having proprietary interest in land within two hundred (200) feet of any property in question. At this hearing any party may appear in person or by a representative. The hearings of the Board shall be public. However, the Board may recess for discussion but not vote on any case before it.

1300.09 Decisions of the Board

The Board shall decide all applications and appeals within thirty (30) days after the final hearing thereon. A certified copy of the Board's decision shall be transmitted to the Zoning Inspector and to the applicant. Such decision shall be binding upon the Zoning Inspector and observed by him, and he shall incorporate the terms and conditions of the same in the permit to the applicant whenever a permit is authorized by the Board.

1300.10 Appeals Based on Alleged Errors or Matters of Interpretation

An appeal to the Board involving an alleged error of interpretation by the Zoning Inspector, or a matter of interpretation, may be taken by any person aggrieved or by an officer of the Municipality affected by any decision of the Zoning Inspector, or the matter of the interpretation.

1300.11 Criteria for Approval of a Change of Nonconforming Uses

To approve a substitution of a new nonconforming use for an existing nonconforming use the Board must find that proposed nonconforming use is substantially similar to the existing nonconforming use in terms of impact on the neighborhood. The Board may impose additional requirements upon the new nonconforming use as may be considered reasonable to minimize impacts upon surrounding property. An expansion of a nonconforming use may only be approved if it is found that such expansion will not be detrimental to the neighborhood.

1300.12 Expiration of Approval to change Nonconforming Uses

Approval of a change of nonconforming uses shall be deemed to authorize only one particular use. Such approval shall expire if such use has not been instituted in one year or if discontinued for more than two (2) years.

1300.13 Variances

The Board shall have the power to authorize such variances from the dimensional provisions or requirements of this ordinance as will not be contrary to the public interest.

1300.14 Requirements to Grant a Variance

In authorizing a variance, the Board may attach conditions and require such guarantee or bond as it may deem necessary to assure compliance with the objectives of this ordinance. The Board may grant a variance in the application of the provisions of the zoning ordinance only if all of the following findings are made:

- A. That there are unique physical circumstances or conditions, including irregularity, narrowness, or shallowness of lot size or shape, or exceptional topographical or other physical conditions that do not apply generally to other properties in the neighborhood or district in which the property is located.
- B. That because of such physical circumstances or conditions the property cannot be developed in strict conformity with the provisions of the zoning ordinance and that the authorization of a variance is therefore necessary to enable reasonable use of the property.
- C. That such unique conditions have not been created by the appellant.
- D. That the variance, if authorized, will not alter the essential character of the neighborhood or district in which the property is located, nor substantially or permanently impair the appropriate use or development of adjacent property, nor be detrimental to the public welfare.
- E. That the variance, if authorized, will represent the minimum variance that will afford relief and will represent the least modification possible of the regulation in issue.

1300.15 Appeals For a Certificate of Appropriateness

According to Section 407.8, the Board may reverse, affirm, or modify a decision made by the design review Board concerning a certificate of appropriateness, by applying the criteria established in Section 407.6.

ARTICLE XIV AMENDMENTS

1400.01 General

The Council may amend or change the number, shape, area, or regulations of or within any district, but no such amendment or change shall become effective unless the ordinance proposing it is first submitted to the Planning Commission for approval, disapproval, or suggestions and the Commission is allowed a reasonable time, not less than thirty days, for consideration and report

1400.02 Notice and Public Hearing

Before any zoning ordinance, measure, regulation, or amendments thereto be passed, the Council shall hold a public hearing thereon, and shall give at least thirty days' notice of the time and place thereof in a newspaper of general circulation in the Village. If the ordinance, measure or regulation intends to rezone or redistrict ten (10) or less parcels of land, as listed on the tax duplicate, written notice of the hearing shall be mailed by the clerk of the Council, by first class mail, at least thirty days before the date of the public hearing to the owners of property within and contiguous to and directly across the street from such parcel or parcels to the addresses of such owners appearing on the County Auditor's current tax list or the Treasurer's mailing list and to such other list or lists that may be specified by the Council. The failure of delivery of such notice shall not invalidate any such ordinance, measure or regulation. During such thirty days the text or copy of the text of such ordinance, measure, or regulation, together with the maps or plans or copies thereof forming part of or referred to in such ordinance, measure, or regulation and the maps, plans, and reports submitted by the Planning Commission, shall be on file, for public examination, in the office of the Clerk of the Council or in such other office as is designated by the Council. No such ordinance, measure, or regulation that violates, differs from, or departs from the plan or report submitted by the Commission shall take effect unless passed or approved by not less than three-fourths of the membership of the Council.

1400.03 Application Fees

At the time that an application for a change of zoning districts is filed there shall be deposited with the municipality a fee as specified in a resolution passed by the Village Council.

ARTICLE X VALIDITY AND SEPARABILITY

If any article, section, subsection, paragraph, sentence or phrase of this ordinance is for any reason held to be invalid by a court of competent jurisdiction, such decision shall not affect the validity of the remaining portions of this ordinance.

ARTICLE XI EFFECTIVE DATE

This ordinance shall become effective from and after the date of its approval and adoption, as provided by law.